

CWIEME CHICAGO 2008

RALE WORKSHOP

This Rale workshop approaches the design of transformers for a Transformer Manufacturer from the point of view of a buyer and/or user of transformers. To demonstrate these applications, Rale selected about 20 design examples as follows:

- Designing inherently short-circuit-proof, potted safety transformers 12V, 0.166A in accordance with IEC 61558
- Designing inherently current limited, potted safety transformers 10V, 5A in accordance with UL 1585 Class 2
- Designing inherently current limited single phase transformer 24V, 100A with integrated inductor
- Designing high voltage ,potted transformers 10kV, 0.1A, 1500Hz
- Designing mixed operation mode transformer, 230V/115V, 10A in autotransformer and 230V/115V, 10A galvanic separated connection
- Designing three phase autotransformer, for 3x400V/3x380V, 10kVA output power and 25% one phase unsymmetrical load
- Designing three phase, low inrush current universal autotransformer for 3x208V/120V, 50/60Hz, 9A
- Designing rectifier transformer for battery charger 6Vdc, 40dc
- Designing rectifier transformer for welding with 26Vdc, 200Adc
- Designing the audio transformer for loudspeaker 25W, 16_Ohm
- Designing flyback transformer for capacitor charger 10kVdc, 0.1 μ F, 50W
- Designing a 500 kVA, 60Hz, K-Factor, three phase dry transformer with cooling channels?
- Designing a 3 phase, 50/60Hz rectifier transformer (YYD to suppress 5. and 7. harmonics) with 2 parallel connected bridge rectifiers, for $U_{dc} = 400V$ and $I_{dc} = 1000A$
- Designing a 12Vdc, 30kAdc Rectifier Transformer
- Designing a 1600kVA/35kVA, 50Hz Distribution Oil Transformer
- Designing Water Cooled Inverter Filter Choke, 0.5mH, 600Arms, 60Hz
- Power Factor Correction Chokes
- Commutation Chokes
- Smoothing Chokes
- LC-Filter Chokes
- Current Compensated Chokes

The concept is to assist the Transformer Manufacturers to incorporate transformer designs as an integral part their business and also for the Transformer Manufacturers to get a better overview about new applications that could be easily integrated in their production using Rale's design software. For this reason Rale has included very powerful design guidelines, for instance relating to water cooling, high voltage spacing, etc.

Table of Contents

RALE Design System Seminar

1. Short Circuit / Design1 Designing inherently short-circuit-proof, potted safety transformers 12V, 0.166A in accordance with IEC 61558
2. Short Circuit / Design2 Designing inherently current limited, potted safety transformers 10V, 5A in accordance with UL 1585 Class 2
3. Short Circuit / Design3 Designing inherently current limited single phase transformer 24V, 100A with integrated inductor
4. High Voltage/ Design1 Designing high voltage ,potted transformers 10kV, 0.1A, 1500Hz
5. Autotransformer / Design1 Designing mixed operation mode transformer, 230V/115V, 10A in autotransformer and 230V/115V, 10A galvanic separated connection
6. Autotransformer / Design2 Designing three phase autotransformer, for 3x400V/3x380V, 10kVA output power and 25% one phase unsymmetrical load
7. Inrush Current / Design1 Designing three phase, low inrush current universal autotransformer for 3x208V/120V, 50/60Hz, 9A
8. Battery Charger/ Design1 Designing rectifier transformer for battery charger 6Vdc, 40dc
9. Welding/ Design1 Designing rectifier transformer for welding with 26Vdc, 200Adc
10. Audio/ Design1 Designing the audio transformer for loudspeaker 25W, 16_Ohm
11. Capacitor Charger / Design1 Designing flyback transformer for capacitor charger 10kVdc, 0.1 μ F, 50W
12. K-Factor Transformer/ Design 1 Designing a 500 kVA, 60Hz, K-Factor, three phase dry transformer with cooling channels?
13. Rectifier Transformer/ Design 1 Designing a 3 phase, 50/60Hz rectifier transformer (YYD to suppress 5. and 7. harmonics) with 2 parallel connected bridge rectifiers, for $U_{dc} = 400V$ and $I_{dc} = 1000A$
14. Rectifier Transformer/ Design 2 Designing a 12Vdc, 30kAdc Rectifier Transformer
15. Distribution Transformer Designing a 1600kVA/35kVA, 50Hz Distribution Oil Transformer

Choke Designs located in the back pocket of the folder

Designing Water Cooled Inverter Filter Choke, 0.5mH, 600Arms, 60Hz

Power Factor Correction Chokes

Commutation Chokes

Smoothing Chokes

LC-Filter Chokes

Current Compensated Chokes

Topic1 / Design1

Designing inherently short-circuit-proof, potted safety transformers 12V, 0.166A in accordance with IEC 61558

Input parameters

Primary	Voltage	120V +-10%, 60Hz, sine wave
	Wire	Cu, round, single insulated
	Layer insulation	No
	Final insulation	No
Secondary	Nominal output voltage	12V
	Nominal output current	0.15A @ 80 Ohm
	Wire	Cu, round, single insulated
	Layer insulation	No
Core	Size	EI 25, stack $\frac{3}{4}$, no holes
	Steel	
		M45, alternate stacking, not annealed
Bobbin	Size	For core EI 25/(3/4)
	Typ	Double section
Case	Size	1" x 0.75" x 1.25", potted
Design	Insulation class	B, max. operating temperature 120C, max. short-circuit temperature 175C
	Ambient temperature	40C
	Regulation	100%, for min short-circuit current and max. output power
	Induction	1.1T, to limit the no-load temperature due to the high value of the regulation

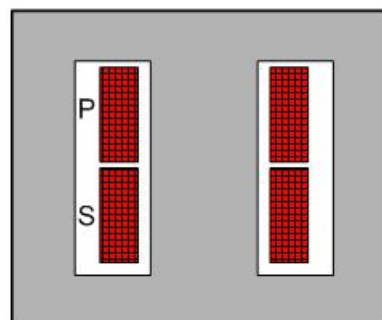

#*0	DIAGNOSE	Page 0
Name	:1 X EI 25/(3/4) 1280-0	
Steel	-:M45 Gauge 24 / 0.0250"	
Number of Sections	-:2	
max.Cu-Fill Factor	∴:89.9	
max. parallel Wires	:1	
Induction on Load	T:1.274	
Max. Induction	T:1.628	
Max.Cu-Temp.rise on load	°K:49.	
Max.Cu-Temp.rise no-load	°K:30.4	
Regulation	∴:98.8	
I [^] Inrush/I [^] nom-Factor	*:4.	
Input Current No-Load	∴:91.7	

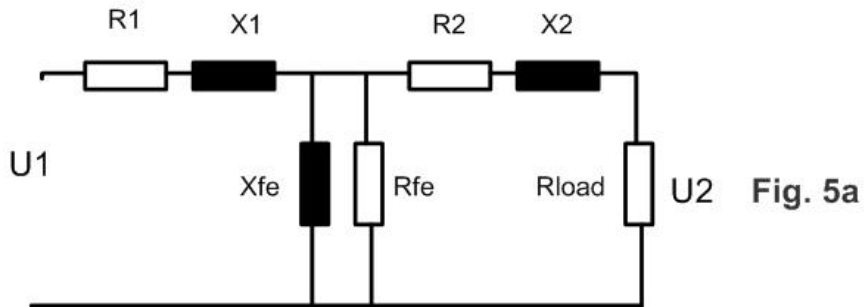

Low Frequency Scheme of a Transformer

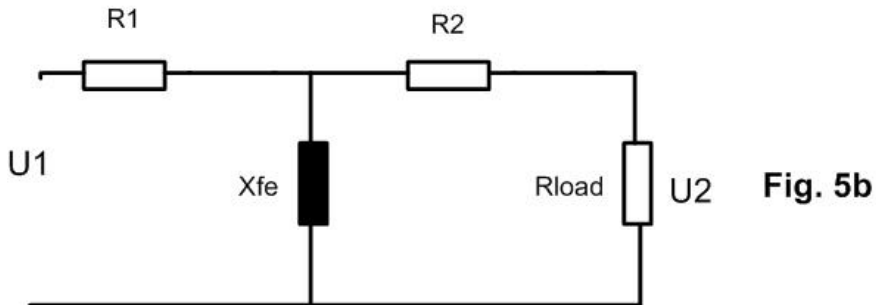

Low Frequency, Low Power (<5VA)
Scheme of a Transformer

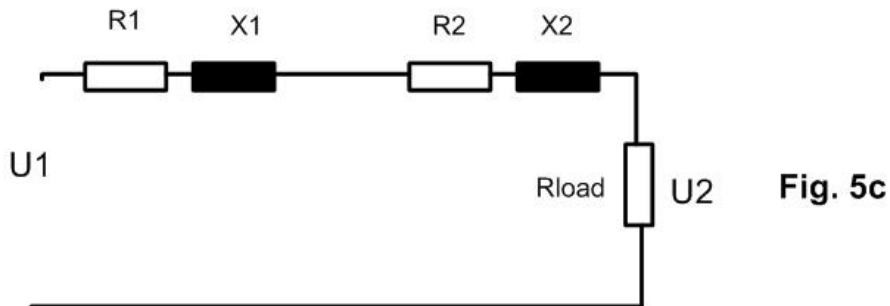

Low Frequency, > 5VA Power, Low Induction (< 1T)
Scheme of a Double-Section Transformer

Fig. 5

PRIMARY	U(V)	I(A)	SECOND.	1---	2---	3---	4---	5---	6---	7---	8---
Circuit-:1	1.		Circuit-:11								
Overvlt*:1.10	.		Volta. U:12.								
Wire :0.0	.		Curre. A:.166								
I/L. mil:0.	.		Wire :0								
I/E. mil:0.	.		I/L mil:0.0								
Formfac.:1.11	.		I/E mil:0.0								
Fre.Hz:60	.										
dI/Io :100	.										

Regulat. %:100.0	Steel	-:17	Cooling	*:1.00	Bobbin	-:2
Udiode U:0.8	Induction T:1.27		Force ft/s:0.00		P/S-Order	-:1
dUdiode U:.1	Remanence *:0.35		Bracket	-:0	Rac/Rdc	*:1.05
Ripple %:5.	W/kg *:1.00		Radiator	-:0	Space	*:0.90
Tmp. Amb. °C:40	UAr/kg *:1.00		Chassis	-:1.00	Vertical	-:1
Tmp.rise °K:75	Gap *:1.00		Channel in:0.00		Horizontal	-:1
Time 1 Min:30.0	Annealed -:0		Cu-Surface*:1.00		Impregnat.	-:2
Load 1 *:1.0	Stacking *:1.00		Rth-uarni.*:1.00		Spread	%:0
Time 2 Min:30.0	Hole -:1		Rth-comp. *:2.00		Selection	-:2
Load 2 *:1.0	Assembly -:1		Case	-:1	Criterion	-:1

CIRCUIT:

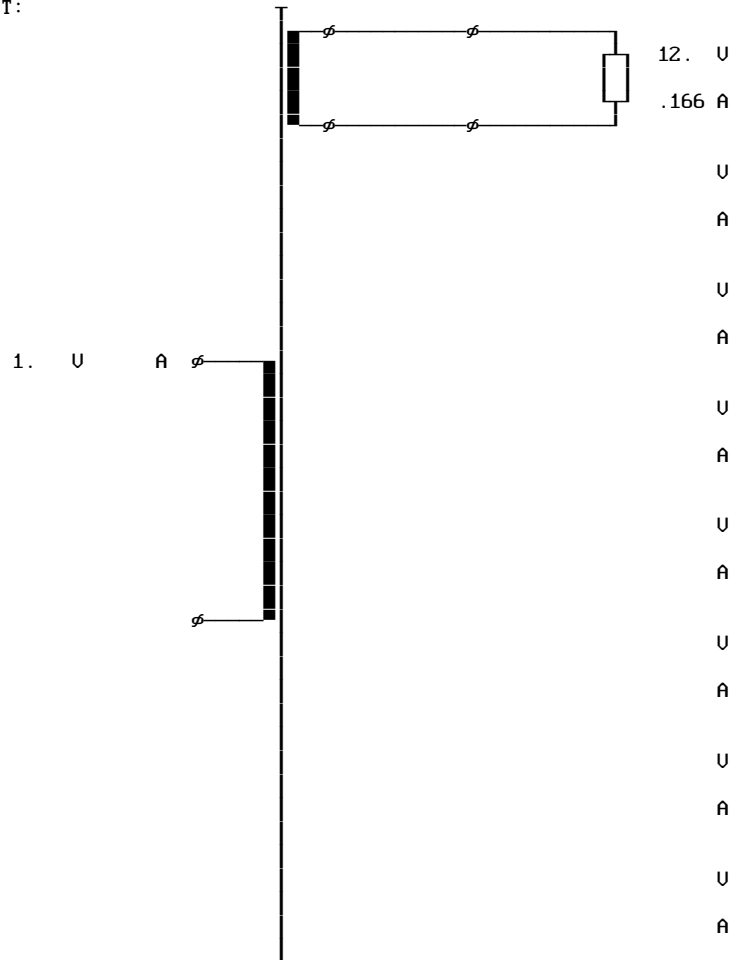

Name : 1XEI 25/(3/4) 1280-0
 Steel : M45 Gauge 24 / 0.0250"

/25.59

| F | B | A | B | F | | D |

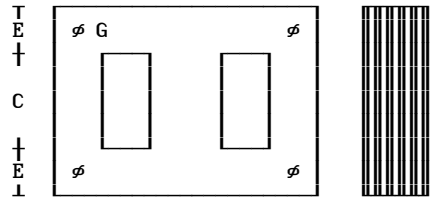

Weight lb: .1
 Gap total in: 0.000
 A-Limb in: 0.25
 B-Width in: 0.25
 C-Height in: 0.50
 D-Stack in: 0.75
 E-Yoke 1 in: 0.13
 F-Yoke 2 in: 0.13
 G-Hole in: 0.00
 Radiator Fin : 0
 Radiator Chan. : 0
 a1 cm: 0.33
 a2 cm: 0.73
 d1 cm: 0.81
 d2 cm: 1.24
 l cm:
 lp cm: 0.20
 ls cm: 0.20
 Margin cm: 0.04

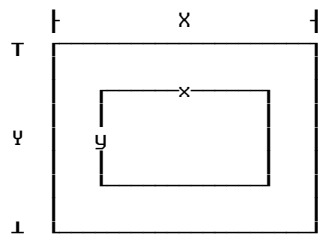
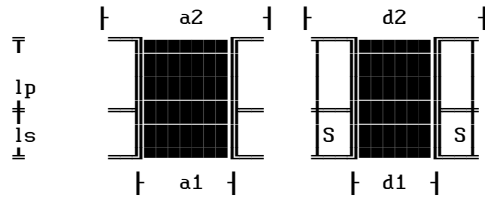

X- Length 1 in: 1.03
 Y- Width 1 in: 0.78
 Z- Height 1 in: 1.28
 x- Length 2 in: 0.78
 y- Width 2 in: 0.53
 z- Height 2 in: 0.25
 w- Thickness in: 0.01
 Material :
 Potted :

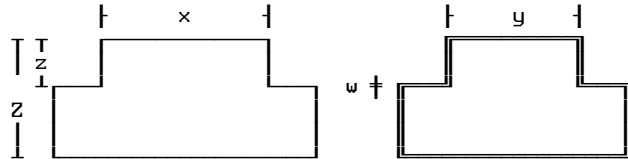

	Typ	Windun	MTI	DN	DN	Par	D/φ mil	B/φ mil	W/L	L	I/L mil	I/E mil	Weight lb	RWH %
1	1	20.1	C00	20.0	20.0	1	32.	32.	5	4.1	.	.	.015	89.
2														
3														
4														
5														
6														
7														
8														
1	11	481.6	C00	33.5	33.5	1	6.7	6.7	25	19.	.	.	.015	78.
2														
3														
4														
5														
6														
7														
8														
TOTAL													.029	89.

07-26-2008/20:14:17	General Data	Page 3
<p>NOMINAL OPERATION at Temperature °C 88.8 and Overvoltage 1.10</p> <p>Output Power on Load W:2.42 Output Power of Transfor. W:2.42</p> <p>Cu Losses W:2.55 Fe-Losses active W:.33</p> <p>Short-Circuit-Volt. cold %:41.52 Regulation %:98.81</p> <p>Instantaneous pow. .5/95& W:3. Efficiency of Transformer %:45.67</p> <p>dT Fe average Surface °K:43.8 dT primary °K:49.</p> <p>dT Case aver. Surface °K:40.5 dT secondary °K:48.7</p>		
<p>0.061Ω 0.004Ω .8 U 0.057Ω 0.004Ω .6 U 0.89 °</p> <p>27.23% 1.7 % 72.9 % 25.19% 1.7 % 50.3 %</p> <p>1 1.1 U 2 Ω 38997 Ω 1 Ω 0.126 Ω</p> <p>100 % 862.8 % 6.803 nF 412.5 % 0.126 Ω</p> <p>4.886 A 6.803 nF 4.38 A</p> <p>111.6 % 1.274T 100 %</p>		
<p>DUTY CYCLE OPERATION at Amb. Temperature °C 40. and Overvoltage 1.10</p> <p>dT Fe average Surface °K:43.9 dT primary °K:49.</p> <p>dT Gehäuse av. Surface °K:40.6 dT secondary °K:48.7</p>		
<p>NO LOAD OPERATION at Amb. Temperature °C 40. and Overvoltage 1.10</p> <p>Losses active W:1.66 Losses reactive UAr:4.64</p> <p>Current factor %:91.68 Induction T:1.628</p> <p>dT Fe average Surface °K:27.6 dT primary °K:30.4</p> <p>dT Gehäuse av. Surface °K:25.5 Resonance frequency kHz:38.9</p>		
<p>SHORT-CIRCUIT OPERATION at Amb. Temperature °C 40. and Overvoltage 1.10</p> <p>Losses active W:12.89 Losses reactive UAr:1.16</p> <p>Current factor cold %:240.9 Induction T: 822</p> <p>dT Fe average Surface °K:104.7 dT primary °K:121.3</p> <p>dT Gehäuse av. Surface °K:95.5 dT secondary °K:121.</p>		
<p>PRIMARY (Tap:1) 1---- 2---- 3---- 4---- 5---- 6---- 7---- 8----</p> <p>Voltage Input/Output U:1.1</p> <p>Out. Voltage no load U:</p> <p>Current Input/Output A:4.886</p> <p>Load on output Ω:</p> <p>Power factor of load :</p> <p>Current in segment A:4.886</p> <p>Current density A/in²:6099.</p> <p>Icc-Current cold A:11.77</p> <p>Io -Current A:4.479</p> <p>Inrush Current peak ^A:27.59</p> <p>Inrush Current rms A:11.3</p> <p>Cu-Losses W:1.5</p> <p>Resistance cold Ω:.0491</p> <p>Reactance Ω:.0038</p> <p>Eddy-Current Factor :1.</p>		
<p>SECONDARY 1---- 2---- 3---- 4---- 5---- 6---- 7---- 8----</p> <p>Output Voltage U:13.24</p> <p>Output Current A:0.183</p> <p>Out. Voltage no load U:24.5</p> <p>Sec. Voltage U:13.24</p> <p>Sec. Current A:0.183</p> <p>Current density A/in²:5192.</p> <p>Sec. Voltage cold U:14.7</p> <p>Load on output Ω:72.28</p> <p>Power factor of load :1.000</p> <p>Icc cold A:0.48</p> <p>Cu-Losses warm W:1.088</p> <p>Resistance cold Ω:25.99</p> <p>Reactance Ω:2.194</p> <p>Eddy-Current Factor :1.</p> <p>Capacitor mF:.</p>		

Topic1 / Design2

Designing inherently current limited, potted safety transformers 10V, 5A in accordance with UL 1585 Class 2

Input parameters

Primary	Voltage	120V +-10%, 60Hz, sine wave
	Wire	Cu, round, single insulated
	Layer insulation	No
	Final insulation	No, due to the potting
Secondary	Nominal and no-load output rms voltage	10V on load, 15V no-load
	Nominal and max. short-circuit rms output current	5A @ 2 Ohm and <8A @ 0.03 Ohm after 60 sec in short-circuit operation mode
	Wire	Cu, round, single insulated
	Layer insulation	No
	Final insulation	No, due to the potting
Core	Size	EE 125/2 with 2 E parts from core EI 125
	Steel	M45, alternate stacking, not annealed
Bobbin	Size	2 EI 125/2 single section bobbins
Case	Size	This transformer is designed without case. With the case the temperature rise will be lower.
Design	Insulation class	B, max. operating temperature 120C, max. short-circuit temperature 175C
	Ambient temperature	40C
	Regulation	50%, in order to limit the no-load output voltage (<15Vrms)
	Induction	<0.3T, to limit the short-circuit current (<8A) and losses with a very high leaking reactance

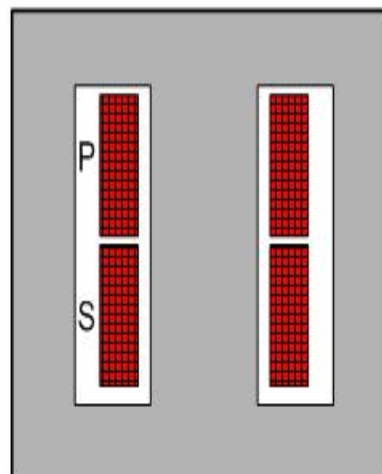
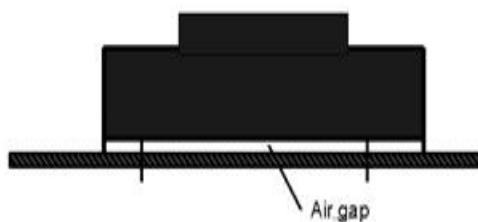

#*0	DIAGNOSE	Page 0
Name	:1 X EIL 125/(2)-5/7	
Steel	-:M45 Gauge 24 / 0.0250"	
Number of Sections	-:2	
max.Cu-Fill Factor	∴84.1	
max. parallel Wires	:1	
Induction on Load	T:0.243	
Max. Induction	T:0.312	
Max.Cu-Temp.rise on load	°K:25.9	
Max.Cu-Temp.rise no-load	°K:3.8	
Regulation	∴52.7	
I [^] Inrush/I [^] nom-Factor	*:.	
Input Current No-Load	∴2.6	

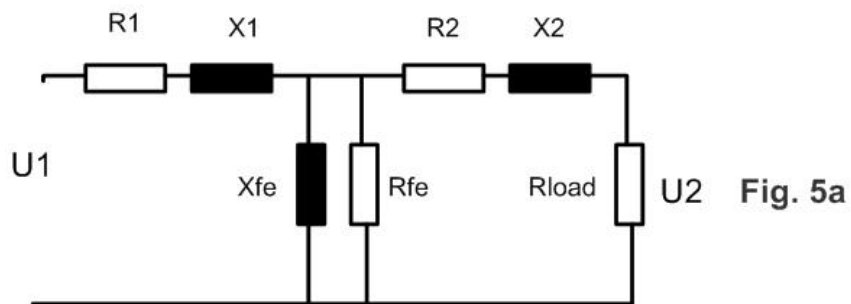

Low Frequency Scheme of a Transformer

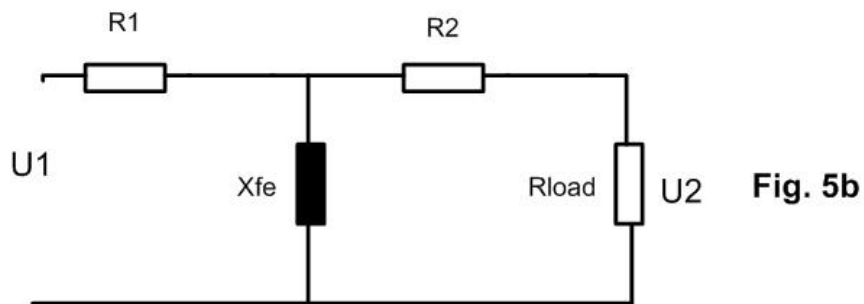

Low Frequency, Low Power (<5VA)
Scheme of a Transformer

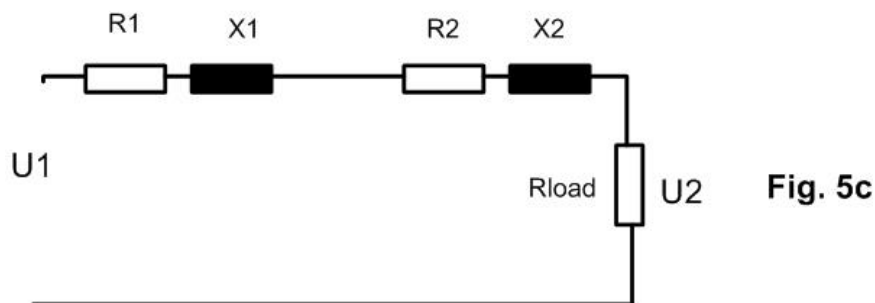

Low Frequency, > 5VA Power, Low Induction (< 1T)
Scheme of a Double-Section Transformer

Fig. 5

**

Name : 1XEIL 125/(2)-5/7
 Steel : M45 Gauge 24 / 0.0250"

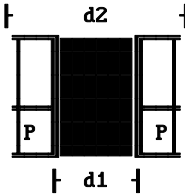
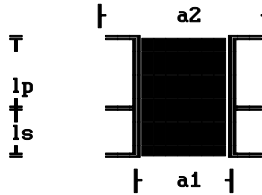
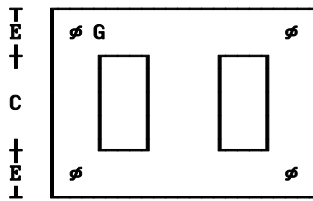

Weight /25.59
 lb:7.74
 Gap total in:0.000
 A-Limb in:1.25
 B-Width in:0.63
 C-Height in:3.75
 D-Stack in:2.01
 E-Yoke 1 in:0.63
 F-Yoke 2 in:0.63
 G-Hole in:0.219
 Radiator Fin :0
 Radiator Chan. :0
 a1 cm:1.39
 a2 cm:2.46
 d1 cm 2.24
 d2 cm 3.50
 l cm:
 lp cm:1.45
 ls cm:2.04
 Margin cm:0.08

X- Length 1 in:
 Y- Width 1 in:
 Z- Height 1 in:
 x- Length 2 in:
 y- Width 2 in:
 z- Height 2 in:
 w- Thickness in:
 Material :
 Potted :

	Typ	Windun	MTI	DN	DN	Par	D/φ mil	B/φ mil	W/L	L	I/L mil	I/E mil	Weight lb	RWH %
1	1	910.	C00	21.0	21.0	1	28.5	28.5	65	13.	.	.	1.596	82.
2														
3														
4														
5														
6														
7														
8														
1	11	115.0	C00	13.5	13.5	1	67.9	67.9	19	5.9	.	.	1.148	84.
2														
3														
4														
5														
6														
7														
8														
TOTAL													2.743	84.

NOMINAL OPERATION at Temperature °C 50.1 and Overvoltage 1.00
 Output Power on Load W:49.3 Output Power of Transform. W:49.3
 Cu Losses W:9.5 Fe-Losses active W:1.
 Short-Circuit-Volt. cold %:63.15 Regulation %:52.72
 Instantaneous pow. .5/958 W:28.6 Efficiency of Transformer %:82.44
 dT Fe average Surface °K:21.4 dT primary °K:24.4
 dT Case aver. Surface °K:. dT secondary °K:25.9

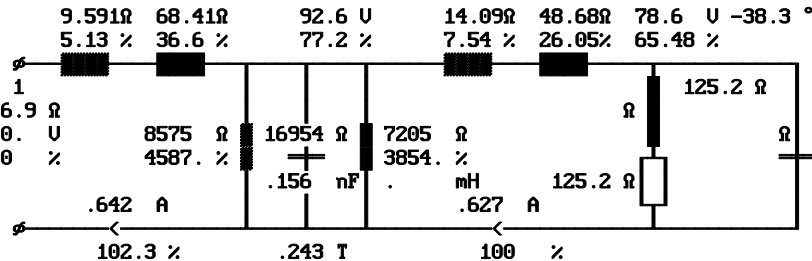

DUTY CYCLE OPERATION at Amb.Temperature °C 25. and Overvoltage 1.00
 dT Fe average Surface °K:21.4 dT primary °K:24.4
 dT Gehäuse av. Surface °K:. dT secondary °K:25.9

NO LOAD OPERATION at Amb.Temperature °C 25. and Overvoltage 1.00
 Losses active W:1.45 Losses reactive UAr:1.4
 Current factor %:2.62 Induction T:.312
 dT Fe average Surface °K:4. dT primary °K:3.8
 dT Gehäuse av. Surface °K:. Rezonance frequency kHz:2.9

SHORT-CIRCUIT OPERATION at Amb.Temperature °C 25. and Overvoltage 1.00
 Losses active W:21.01 Losses reactive UAr:120.1
 Current factor cold %:158.4 Induction T:.132
 dT Fe average Surface °K:44.2 dT primary °K:52.5
 dT Gehäuse av. Surface °K:. dT secondary °K:56.3

PRIMARY (Tap:1) 1---- 2---- 3---- 4---- 5---- 6---- 7---- 8----
 Voltage Input/Output U:120.
 Out. Voltage no load U:
 Current Input/Output A:0.642
 Load on output Ω:
 Power factor of load :
 Current in segment A:0.642
 Current density A/in²:1006.
 Icc-Current cold A:1.02
 Io -Current A:0.017
 Inrush Current peak ^A:0.
 Inrush Current rms A:0.
 Cu-Losses W:4.
 Resistance cold Ω:8.502
 Reactance Ω:68.41
 Eddy-Current Factor :1.01

SECONDARY 1---- 2---- 3---- 4---- 5---- 6---- 7---- 8----
 Output Voltage U:9.93
 Output Current A:4.965
 Out. Voltage no load U:15.05
 Sec. Voltage U:9.93
 Sec. Current A:4.965
 Current density A/in²:1371.
 Sec. Voltage cold U:10.1
 Load on output Ω:2.
 Power factor of load :1.000
 Icc cold A:7.91
 Cu-Losses warm W:5.55
 Resistance cold Ω:.1897
 Reactance Ω:.7776
 Eddy-Current Factor :1.06
 Capacitor mF:.

Topic1 / Design3

Designing inherently current limited single phase transformer 24V, 100A with integrated inductor

General information

There are 2 constructions for creating a transformer with an integrated inductor:

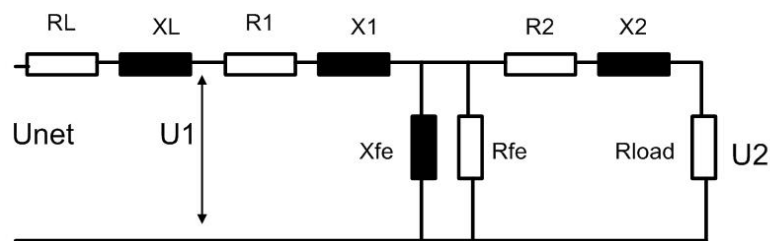

Integrated inductor on the primary side

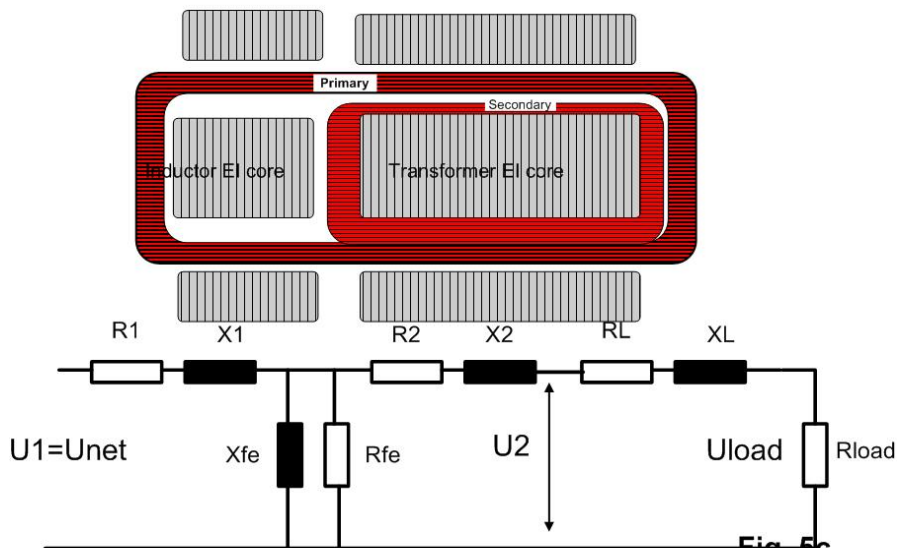
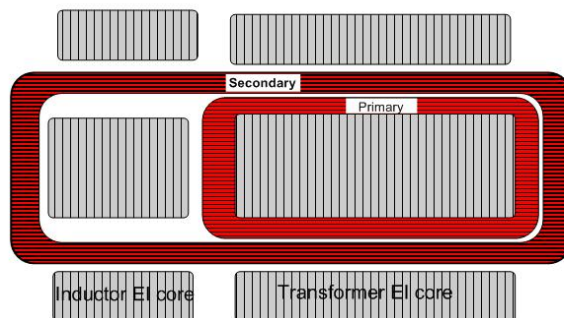

Fig. 5c

Integrated inductor on the secondary side



Normally the construction with the primary outside is used more often due to the fact that it protects the transformer part from voltage spikes, harmonics and it limits the inrush current. Note that the Rale Design Software doesn't support the design of the transformer with the integrated inductor full automatically. You have to design it in 2 steps; first the "transformer" and then the "inductor".

Assume the following operation mode:

- $U_{net} = 400V, 60Hz$
- Short-circuit current has to be $I_{cc} = 2 \times I_{nominal}$; $U_{cc}\% = 50\%$
- 9 minutes @ $I_{nominal}$, 1 minute @ I_{cc}

For this operation mode the "transformer" input voltage is:

$$U_1 = U_{net} \times (1 - (U_{cc}\%/100)^2)^{0.5} = 400 \times (1 - 0.5^2)^{0.5} = 346.4V$$

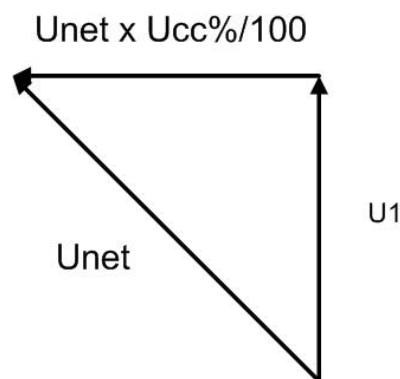

"Transformer" Input parameters

Primary	Voltage	346.4V -10% +24% (no-load at U_{net} +10%), 60Hz, sine wave
	Wire	Cu, round, single insulated
	Layer insulation	5 mil
	Final insulation	5 mil
Secondary	Nominal output rms voltage	24V on load
	Nominal current	100A
	Wire	Cu, square, single insulated
	Layer insulation	No
	Final insulation	12 mil
Core	Size	EI 250/3
	Steel	M19, alternate stacking, not annealed
Tube	Size	2.5 x 3 x 3.7
Design	Insulation class	F, max. operating temperature 155C @ 1 minute 200A and 9 minutes 100A
	Ambient temperature	40C
	Induction	<1.2T, max no-load induction 1.5T

“Transformer” output parameters

#*0	DIAGNOSE	Page 0
Name	:1 X EI 250/(3)	
Steel	-:M19 Gauge 26 / 0.0185"	
Number of Sections	-:3	
max.Cu-Fill Factor	%:90.	
max. parallel Wires	:2	
Induction on Load	T:1.215	
Max. Induction	T:1.235	
Max.Cu-Temp.rise on load	°K:111.	
Max.Cu-Temp.rise no-load	°K:21.1	
Regulation	%:3.1	
I [^] Inrush/I [^] nom-Factor	*:10.1	
Input Current No-Load	%:2.6	

PRIMARY	U(V) I(A)	SECOND. 1---	2---	3---	4---	5---	6---	7---	8---
Circuit-:1	346.	Circuit-:11							
Overvlt*:1.00	.	Volta. U:24.							
Wire :0.0	.	Curre. A:100.							
I/L. mil:5.	.	Wire :3							
I/E. mil:0.	.	I/L mil:0.0							
Formfac.:1.11	.	I/E mil:12.0							
Fre.Hz:60	.								
dI/Io :100	.								

Regulat. %:50.0	Steel -:28	Cooling *:1.00	Bobbin -:3
Udiode U:0.8	Induction T:1.21	Force ft/s:0.00	P/S-Order -:2
dUdiode U:.1	Remanence *:0.35	Bracket -:1	Rac/Rdc *:1.10
Ripple %:5.	W/kg *:1.00	Radiator -:0	Space *:2.00
Tmp. Amb. °C:40	UAr/kg *:1.00	Chassis -:1.00	Vertical -:1
Tmp.rise °K:115	Gap *:1.00	Channel in:0.00	Horizontal -:1
Time 1 Min:1.0	Annealed -:0	Cu-Surface*:1.00	Impregnat. -:2
Load 1 *:2.0	Stacking *:1.00	Rth-uarni. *:1.00	Spread %:0
Time 2 Min:9.0	Hole -:1	Rth-comp. *:2.00	Selection -:1
Load 2 *:1.0	Assembly -:1	Case -:0	Criterion -:2

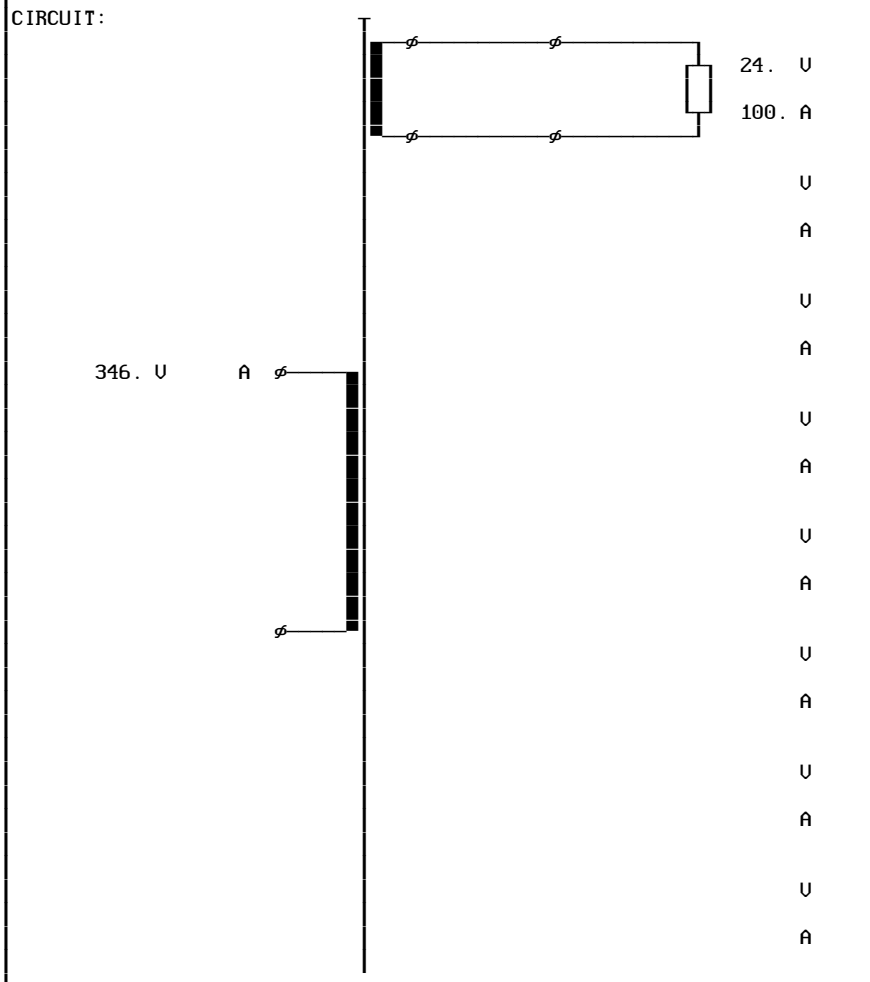

Name : 1XEI 250/(3)
 Steel : M19 Gauge 26 / 0.0185"

| F | B | A | B | F | | D |

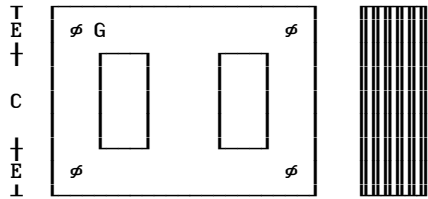

Weight lb: 30.55
 Gap total in: 0.000
 A-Limb in: 2.50
 B-Width in: 1.25
 C-Height in: 3.75
 D-Stack in: 3.00
 E-Yoke 1 in: 1.25
 F-Yoke 2 in: 1.25
 G-Hole in: 0.333
 Radiator Fin : 0
 Radiator Chan. : 0
 a1 cm: 2.75
 a2 cm: 4.93
 d1 cm: 3.25
 d2 cm: 5.93
 l cm: 3.48
 lp cm:
 ls cm:
 Margin cm: 0.14

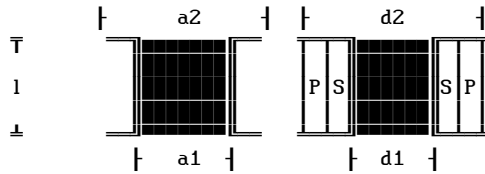

X- Length 1 in:
 Y- Width 1 in:
 Z- Height 1 in:
 x- Length 2 in:
 y- Width 2 in:
 z- Height 2 in:
 w- Thickness in:
 Material :
 Potted :

	Typ	Windun	MTI	DN	DN	Par	D/ ϕ mil	B/ ϕ mil	W/L	L	I/L mil	I/E mil	Weight lb	RWH %
1	1	224.	C00	12.5	12.5	1	76.3	76.3	42	5.2	5.	.	5.362	49.
2														
3														
4														
5														
6														
7														
8														
1	11	16.0	C11	5.0	5.0	2	182.	182.	17	1.8	.	12.	4.513	40.
2														
3														
4														
5														
6														
7														
8														
TOTAL													9.876	90.

NOMINAL OPERATION at Temperature °C 118.8 and Overvoltage 1.00
 Output Power on Load W:2396. Output Power of Transfor. W:2396.
 Cu Losses W:73.07 Fe-Losses active W:32.42
 Short-Circuit-Volt. cold %:2.77 Regulation %:3.06
 Instantaneous pow. .5/95& W:5789. Efficiency of Transformer %:95.78
 dT Fe average Surface °K:58.3 dT primary °K:78.9
 dT Case aver. Surface °K:. dT secondary °K:78.7

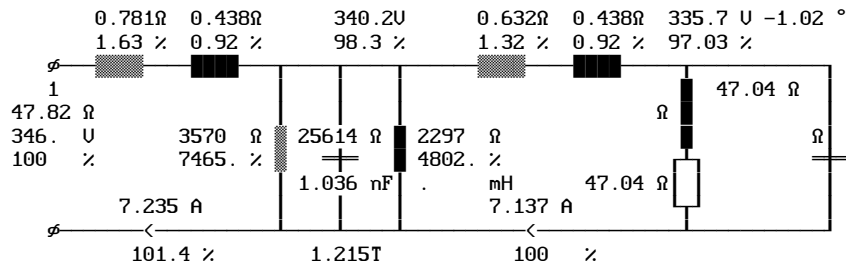

DUTY CYCLE OPERATION at Amb. Temperature °C 40. and Overvoltage 1.00
 dT Fe average Surface °K:77.7 dT primary °K:111.
 dT Gehäuse av. Surface °K:. dT secondary °K:110.7

NO LOAD OPERATION at Amb. Temperature °C 40. and Overvoltage 1.00
 Losses active W:33.56 Losses reactive UAr:56.52
 Current factor %:2.63 Induction T:1.235
 dT Fe average Surface °K:26. dT primary °K:21.1
 dT Gehäuse av. Surface °K:. Rezonance frequency kHz:2.

SHORT-CIRCUIT OPERATION at Amb. Temperature °C 40. and Overvoltage 1.00
 Losses active W:67795 Losses reactive UAr:59834
 Current factor cold %:3612. Induction T:.584
 dT Fe average Surface °K:1477. dT primary °K:2128.
 dT Gehäuse av. Surface °K:. dT secondary °K:2690.

PRIMARY (Tap:1) 1---- 2---- 3---- 4---- 5---- 6---- 7---- 8----
 Voltage Input/Output U:346.
 Out. Voltage no load U:
 Current Input/Output A:7.235
 Load on output Ω:
 Power factor of load :
 Current in segment A:7.235
 Current density A/in²:1582.
 Icc-Current cold A:261.3
 Io -Current A:0.19
 Inrush Current peak ^A:102.9
 Inrush Current rms A:47.54
 Cu-Losses W:40.9
 Resistance cold Ω:.5559
 Reactance Ω:.4381
 Eddy-Current Factor :1.01

SECONDARY 1---- 2---- 3---- 4---- 5---- 6---- 7---- 8----
 Output Voltage U:23.98
 Output Current A:99.91
 Out. Voltage no load U:24.7
 Sec. Voltage U:23.98
 Sec. Current A:99.91
 Current density A/in²:1508.
 Sec. Voltage cold U:24.2
 Load on output Ω:.24
 Power factor of load :1.000
 Icc cold A:3657.
 Cu-Losses warm W:32.18
 Resistance cold Ω:.0022
 Reactance Ω:.0022
 Eddy-Current Factor :1.04
 Capacitor mF:.

^

“Inductor” Input parameters

After the “transformer” design we know the following “inductor” parameters:

- The nominal current $I_{1n} = 7.235A$
- The number of turns and the wire size
- Max. peak value of the current through the “inductor”
 $1.41 \times I_{cc} = 1.41 \times 2 \times 7.235 = 20.4A$
- The core shape and steel
- Frequency $f = 60 \text{ Hz}$

The nominal inductance of the “inductor has to be:

$$L = U_{net} \times U_{cc}\% / 100 / I_{1n} / 2 / \pi / f = 346.4 \times 0.5 / 7.235 / 376 = 0.06366H$$
$$L = 63.66mH \text{ linear up to } = 20.4A$$

In the short-circuit mode of the “transformer” the “inductor” is set under the voltage of 346.4V. Using the formula:

$$U = 4.44 \times f \times W \times B \times K_{fe} \times A_{fe}$$

And:

- $f = 60$
- $W = 224$ (turns of the primary winding)
- $B = 1.5T@20.4A^{\wedge}$
- A_{fe} the cross section of the “inductor” core

We calculate the stack of the “inductor” core 2.5”

Winding	RMS Inductance	63.66mH @ 20.4A [^] &1,5T realized with 224 turns , calculated with “transformer” design
	Wire	Cu, round, single insulated AWG 12.5, calculated with “transformer” design
	Layer insulation	5 mil
	Final insulation	5 mil
	Nominal rms current	100Arms, 60Hz
Core	Size	EI 250/2.5
	Steel	M19, alternate stacking, not annealed
Tube	Size	2.5 x 3 x 3.7
Design	Insulation class	F, max. operating temperature 155C @ 1 minute 200A and 9 minutes 100A
	Ambient temperature	40C
	Induction	<1.2T, max no-load induction 1.5/

“Inductor” output parameters

Name and Type of the Bobbin	:3 /1 X EI 250/(2_5)
Steel	-:M19 Gauge 26 / 0.0185"
Used Space of the Bobbin	∅: 51.4
Number of wires in parallel	:1 at RacRdc : 1.028/0.
Max. Current	Imax A:2.04 20.4 . . . 30.6 . 40.8
Inductance at Imax	mH:62.7 63.3 0. 0. 0. 62.1 0. 61.7
Nominal Induction at Imax	T:0.11 1.14 0. 0. 0. 1.69 0. 2.24
Minimal Induction at Imax	T:0.1 1.02 0. 0. 0. 1.49 0. 1.98
Maximal Induction at Imax	T:0.13 1.33 0. 0. 0. 1.95 0. 2.02
Nominal Current Inom	rms A: 7.23
Inductance at Inom	mH: 63.45 Bei Ith^A: 10.19
Induction at Inom peak	T: .571 Bei Ith^A: 10.19
Max. dT	°K:54.3
Max. dT at Inom	°K:41. at Pcu W: 28.58 and Pfe W: 34.28
Q_Factor at Inom	:44.9 at Pcu W: 28.58

Schema :1.	L(mH) I(A)	1---	2---	3---	4---	5---	6---	7---	8---
L-Type *:2.	61.6 20.4	Harmo. -:1							
Wire -:0.		Curre. A:7.23							
In/L mil:5.		Angle °:0.							
In/E mil:5.									
Al/Cu -:1.									
Fre.Hz:60									
Ripple %:10.									

Q-Factor :50	Steel -:28	Cooling *:1	Bobbin -:3
Cal.Freq.Hz:60	Induction T:1.41	Uentil. m/s:0	Stomach *:1
LQFreq. Hz:60	Plate -:1	Brackets -:1	Rac/Rdc *:1.05
:0	W/kg *:1	Radiator -:0	Space Fac. *:1.9
Amb.Temp. °C:40	UAr/kg *:1	Chassis -:1	Force -:1
Temp.rise °K:115	Gap posit.*:1	Channel in:0.	Windintech.-:1
Time 1 Min:1	Annealed -:1	Cu-Surfac.*:1	Impregnat. -:2
Load 1 *:2	Stack.Fac.*:1	Rth-Uarn. *:1	Full Layer -:0
Time 2 Min:9	Hole -:0	Rth-Comp. *:1	Selection -:1
Load 2 *:1	Core Asse.-:2	Case -:0	Criterion -:2

Type of the Inductance $L=U/I_{eff}/\Omega 1$

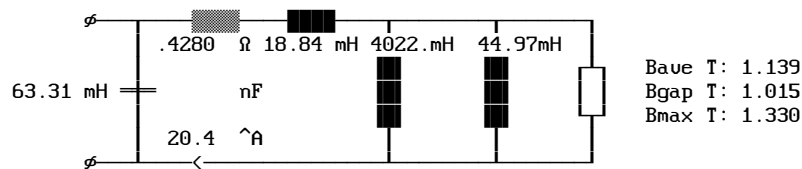

Nominal operation mode at the temperature °C 81.03

Nominal current Inom rms A:7.23	Peak current of Inom ^A:10.19
Al/Cu Losses/phase W:28.58	Steel Losses/phase(actiu) W:34.28
Addy current losses factor :1.028	Q-Factor :44.87
dT Fe (average) °K:35.88	dT Winding (hot spot) °K:41.03
dT Case (average) °K:0.0	dT Windig (average) °K:40.70

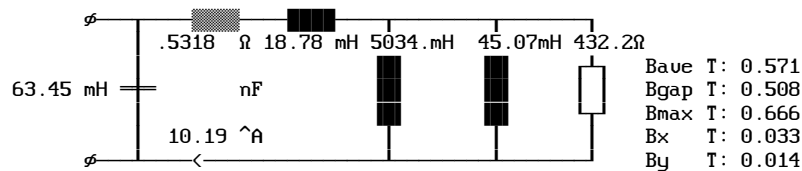

Harmonics :1.	0.	0.	0.	0.	0.	0.	0.
Current rms A:7.23
Al/Cu Losses W:28.58	.	.	.	0.	.	.	.
Fe-Losses W:34.28

Duty cycle operation mode at the amboent temperature °C 94.30

dT Steel (average) °K:43.90	dT Winding (hot spot) °K:54.30
dT Case (average) °K:0.0	dT Winding (average) °K:53.86

Inductance and induction at the impressed peak current

Current ^A	2.04	20.4	.	.	.	30.6	.	40.8	.
Induction ^T	.113	1.14	.	.	.	1.691	.	2.243	.
L=U1/Ω1/I1 mH									
L=U1/Ω1/Ieff mH	62.75	63.31	0.	0.	0.	62.13	0.	61.78	0.
L=ΣU*t/^I mH									
L=dU/Ω1/dI mH									
Leaking Ind. mH	19.17	18.84	0.	0.	0.	19.46	0.	19.66	0.
Gap-Induct. mH	44.51	44.97	0.	0.	0.	44.05	0.	43.76	0.

Name : 1XEI 250/(2.5)

Steel : M19 Gauge 26 / 0.0185"

Weight /18.5

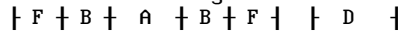

Weight 1b:25.46

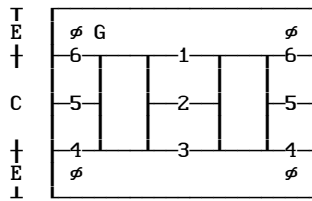

A-Limb(Dia.) in:2.50
 B-Width in:1.25
 C-Height in:3.75
 D-Stack/Dia. in:2.50
 E-Yoke in:1.25
 F-Rearyoke in:1.25
 G-Hole in:0
 Radiator Ribs :0
 Radiator Chann.:0

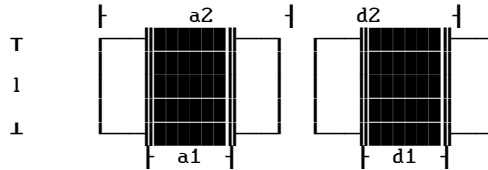

a1 cm:2.75
 a2 cm:4.93
 d1 cm 2.75
 d2 cm 5.43
 l cm:3.48
 lp cm:
 ls cm:
 Margin cm:0.14

X- Lenght 1 in:
 Y- Width 1 in:
 Z- Height 1 in:
 x- Lenght 2 in:
 y- Width 2 in:
 z- Height 2 in:
 w- Thicknes in:
 SPK Material :
 Compound in^3:

Chann./Wind. in:0.00
 Chann.=>core in:0.00

	Windng	T	AWG	AWG	Para	D/φ mil	B/φ mil	Pitch mil	T/L	L	I/L mil	I/E mil	Weight lb	RWH %
1	224.	0	12.5	12.5	1	76.3	76.3		42.4	5.28	5.	5.	4.129	51.
2														
3														
4														

Order	Layers	Turns	Position	1	2	3	4	5	6	7	8
Gap	in			0.11	0.	0.	0.	0.	0.11	0.	0.
Uoltag.U				34.22	345.3	0.	0.	0.	508.3	0.	673.9
Curren.A				1.446	14.46	0.	0.	0.	21.70	0.	28.93

Order :
 Customer :
 Remarks :
 Date :07-28-2008
 Time :23:28:57

Topic2/ Design1

Designing high voltage , potted transformers 10kV, 0.1A, 1500Hz

Input parameters

For this type of transformers the designer uses 2 legs C-core with good 4 mil grain oriented steel. In order to avoid problems with high voltage between primary and secondary windings they have to be wound on the different legs. The transformer has to be potted in a case. The resonance frequency of the transformer capacity and no-load inductance has to be min. 3-5 times higher than the nominal operation frequency. For this reason the designer has to use air gaps in the core, thicker layer insulation and set the secondary winding in a double section bobbin. If possible the core and the tap between 2 secondary sections should be connected to the ground. Note that the resonance frequency can set 2-3 times lower than the operating frequency using an additional secondary winding with capacitive load.

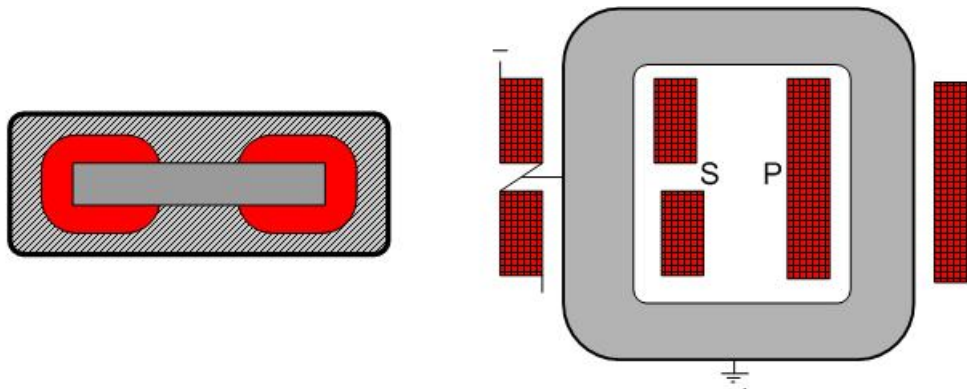

Primary	Voltage	120V +-10%, 1500Hz, rectangular wave form
	Wire	Cu, round, single insulated
	Layer insulation	No
	Final insulation	No
	Winding	Alone per leg on tube potted in case
Secondary	Nominal output voltage	10000V
	Nominal output current	0.1A @ 100 kOhm
	Wire	Cu, round, single insulated
	Layer insulation	>5 mil, in order to limit the layer capacitance for higher resonance frequency
	Final insulation	NO
	Winding	2 Alone per leg on tube, potted in case
Core	Steel	M2, 4 mil
Case	SPotting	Vacuum, no air in the windings
Design	Insulation class	B, max. operating temperature 120C

#*0	DIAGNOSE	Page 0
Name	:2 X SU 60/20.6 gS	M
Steel	-:M2 0.007" => M68-0.18mm	
Number of Sections	-:1	
max.Cu-Fill Factor	∕:87.8	
max. parallel Wires	:1	
Induction on Load	T:0.783	
Max. Induction	T:0.814	
Max.Cu-Temp.rise on load	°K:77.8	
Max.Cu-Temp.rise no-load	°K:48.1	
Regulation	∕:11.7	
I [^] Inrush/I [^] nom-Factor	*:24.8	
Input Current No-Load	∕:32.2	

PRIMARY	U(V) I(A)	SECOND.	1---	2---	3---	4---	5---	6---	7---	8---
Circuit-:1	120.	Circuit-:11								
Overvlt*:1.00	.	Volta. U:9999								
Wire :0.0	.	Curre. A:.1								
I/L. mil:5.	.	Wire :0								
I/E. mil:0.	.	I/L mil:5.0								
Formfac.:1.00	.	I/E mil:10.0								
Fre.Hz:1500	.									
dI/Io :100	.									

Regulat. %:50.0	Steel --:9	Cooling *:1.00	Bobbin --:1
Udiode U:0.8	Induction T:0.78	Force ft/s:0.00	P/S-Order --:3
dUdiode U:.1	Remanence *:0.35	Bracket --:1	Rac/Rdc *:1.25
Ripple %:5.	W/kg *:1.00	Radiator --:0	Space *:0.70
Tmp. Amb. °C:40	UAr/kg *:1.00	Chassis --:1.00	Vertical --:1
Tmp.rise °K:70	Gap *:10.00	Channel in:0.00	Horizontal --:1
Time 1 Min:30.0	Annealed --:1	Cu-Surface*:1.00	Impregnat. --:2
Load 1 *:1.0	Stacking *:0.95	Rth-varni.*:1.00	Spread %:0
Time 2 Min:30.0	Hole --:1	Rth-comp. *:1.00	Selection --:2
Load 2 *:1.0	Assembly --:1	Case --:1	Criterion --:2

CIRCUIT:

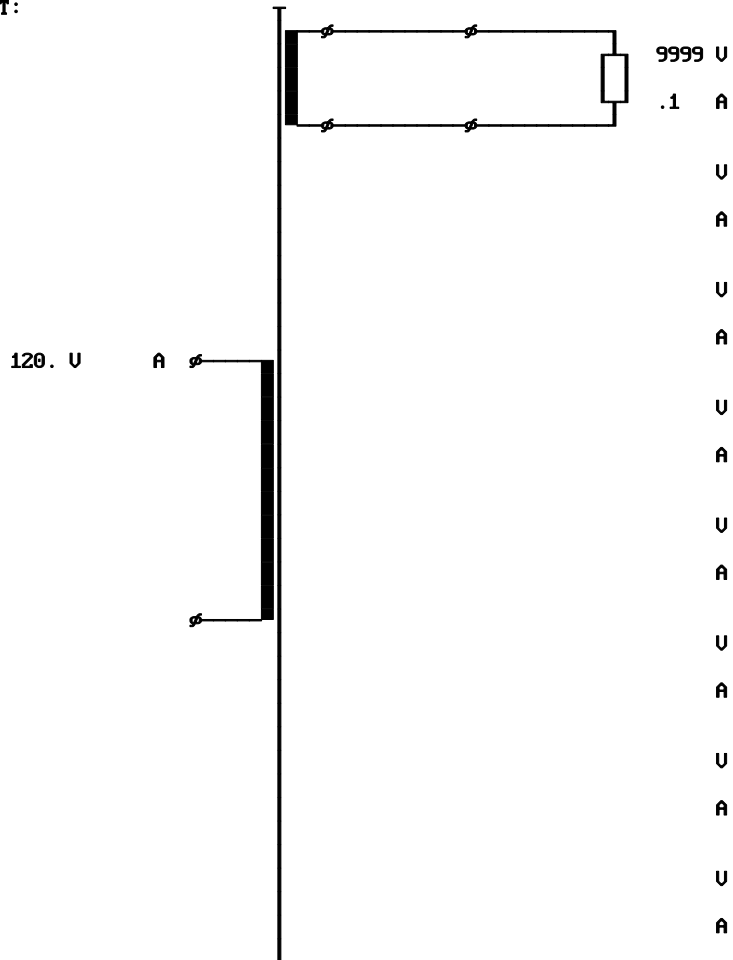

Name :2XSU 60/20.6 gS M
 Steel :M2 0.007" => M68-0.18mm

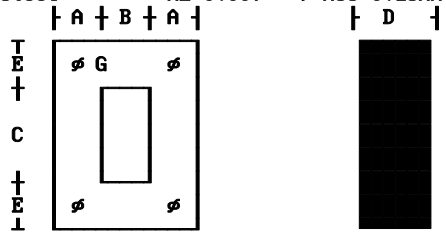

Weight lb:1.34
 Gap total in:0.000
 A-Limb in:0.78
 B-Width in:0.78
 C-Height in:2.47
 D-Stack in:0.81
 E-Yoke 1 in:0.78
 F-Yoke 2 in:0.78
 G-Hole in:0.00
 Radiator Fin :0
 Radiator Chan. :0
 a1 cm:0.91
 a2 cm:1.53
 d1 cm 0.92
 d2 cm 1.79
 l cm:2.22
 lp cm:
 ls cm:
 Margin cm:0.13

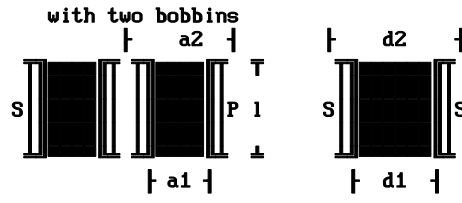

X- Length 1 in:3.21
 Y- Width 1 in:4.11
 Z- Height 1 in:1.65
 x- Length 2 in:0.00
 y- Width 2 in:0.00
 z- Height 2 in:0.00
 w- Thickness in:0.04
 Material :
 Potted :

	Typ	Windun	MTI	DN	DN	Par	D/φ mil	B/φ mil	W/L	L	I/L mil	I/E mil	Weight lb	RWH %
1	1	66.9	C00	12.5	12.5	1	76.3	76.3	27	2.5	5.	.	.437	85.
2														
3														
4														
5														
6														
7														
8														
1	11	6140.2	C00	33.5	33.5	1	6.7	6.7	293	20.	5.	10.	.311	87.
2														
3														
4														
5														
6														
7														
8														
TOTAL													.748	87.

NOMINAL OPERATION at Temperature °C 117.3 and Overvoltage 1.00
 Output Power on Load W:973.8 Output Power of Transfor. W:973.8
 Cu Losses W:15.53 Fe-Losses active W:17.69
 Short-Circuit-Volt. cold %:30.97 Regulation %:11.68
 Instantaneous pow. .5/958 W:366.3 Efficiency of Transformer %:96.7
 dT Fe average Surface °K:78.4 dT primary °K:76.9
 dT Case aver. Surface °K:65.2 dT secondary °K:77.8

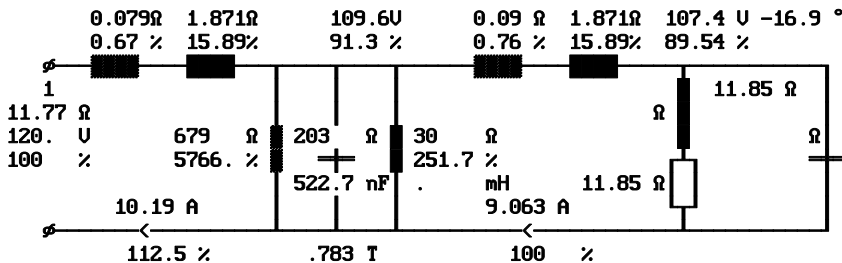

DUTY CYCLE OPERATION at Amb. Temperature °C 40. and Overvoltage 1.00
 dT Fe average Surface °K:78.4 dT primary °K:76.9
 dT Gehäuse av. Surface °K:65.2 dT secondary °K:77.8

NO LOAD OPERATION at Amb. Temperature °C 40. and Overvoltage 1.00
 Losses active W:19.57 Losses reactive UAr:393.5
 Current factor %:32.22 Induction T: .814
 dT Fe average Surface °K:53. dT primary °K:48.1
 dT Gehäuse av. Surface °K:42.9 Rezonance frequency kHz:3.9

SHORT-CIRCUIT OPERATION at Amb. Temperature °C 40. and Overvoltage 1.00
 Losses active W:117.5 Losses reactive UAr:3948.
 Current factor cold %:322.9 Induction T: .424
 dT Fe average Surface °K:6231. dT primary °K:6529.
 dT Gehäuse av. Surface °K:5754. dT secondary °K:6855.

PRIMARY (Tap:1) 1---- 2---- 3---- 4---- 5---- 6---- 7---- 8----
 Voltage Input/Output U:120.
 Out. Voltage no load U:
 Current Input/Output A:10.19
 Load on output Ω:
 Power factor of load :
 Current in segment A:10.19
 Current density A/in²:2229.
 Icc-Current cold A:32.92
 Io -Current A:3.284
 Inrush Current peak ^A:356.3
 Inrush Current rms A:138.9
 Cu-Losses W:8.2
 Resistance cold Ω:0.0453
 Reactance Ω:1.871
 Eddy-Current Factor :1.25

SECONDARY 1---- 2---- 3---- 4---- 5---- 6---- 7---- 8----
 Output Voltage U:9867.
 Output Current A:0.099
 Out. Voltage no load U:10456
 Sec. Voltage U:9867.
 Sec. Current A:0.099
 Current density A/in²:2798.
 Sec. Voltage cold U:9898.
 Load on output Ω:99990
 Power factor of load :1.000
 Icc cold A:0.34
 Cu-Losses warm W:7.36
 Resistance cold Ω:542.2
 Reactance Ω:15783
 Eddy-Current Factor :1.
 Capacitor mF:.

About spacing within a high voltage “dry” transformer

In order to avoid corona and partial discharging within a transformer we have to follow some very important rules about the **value** (V/cm) and the **form** (V/cm²) of the electrical field.

1. The electrical field between 2 parallel, naked wires with the radius R, in air with temperature 25C and pressure 1 at, that will produce the corona effect can be calculated with following formula:

$$E_c = 33.7 \times (1 + 0.242/R^{0.5}) \text{ in kV/cm}$$

2. The most critical form of the electrical field for corona has 2 parallel, naked wires. Note that the same form has the configuration of one wire and one plate. All other configurations of electrodes with the same radius and distances as 2 parallel, naked wires have less critical form of electrical field.

The most critical configurations for corona within a transformer are shown in the following picture.

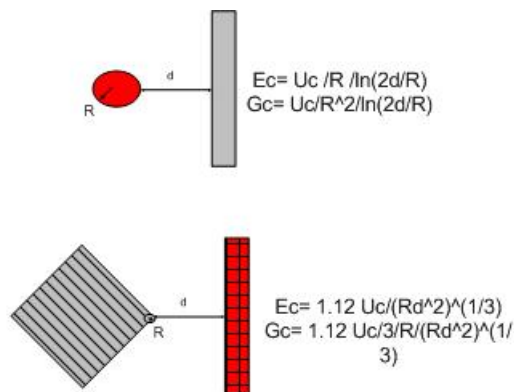

Example 1

Find the voltage between the wire and plate that will produce the corona the following parameters of the configuration:

- R = 40mil = 0.1016cm
- D = 1 in = 2.54cm

This is the electrical field that will produce the corona:

$$E_c = 33.7 (1 + 0.242/0.1016)^{0.5} = 59.28 \text{ kV/cm}$$

This is the voltage between the wire and the plate that will produce the electrical field 59.28 kV/cm and corona:

$$U_c = E_c R \ln(2d/R) = 59.28 * 0.1017 \ln(5.08/0.1016) = 23.56 \text{ kV}$$

Example 2

Find the voltage between the corner of the core and the winding that will produce the corona the following parameters of the configuration:

- $R = 40\text{mil} = 0.1016\text{cm}$
- $D = 1\text{ in} = 2.54\text{cm}$

Out of the first example we know $U_c = 23.56\text{kV}$ and calculate the gradient of the magnetic field for the configuration wire-plate.

$$G_c = U_c / R^2 / \ln(2d/R) = 238 \text{ kV/cm}^2$$

In order to get corona in the configuration core-winding the gradient of magnetic field has to have the value of 238 kV/cm^2 and the voltage between the winding and the core has to be:

$$1.12 U_{c-w-c} / 3R / (Rd^2)^{1/3} = 238$$

And

$$U_{c-w-c} = 63 \text{ kV} > 23.56 \text{ kV}$$

Note that the radius of the core corner is smaller than $40 \text{ mil} = 0.1016\text{cm}$.

About spacing within a high voltage potted transformer

Normally all small power, high voltage transformers are potted in a case. The check in procedure of spacing has more steps:

1. Selection of the best representative model of configuration and calculation of the max. gradient of the electrical field
2. Calculation the dimensions of the high voltage screened cable with the same gradient of the magnetic field as calculated in the step 1, using the formula :

$$G_c = U_o / R_i^2 / \ln(2(R_o)/R_i)$$

3. Selection the resin with a high non-linear specific ohmic conductivity

$$Gama = AE^n$$

4. Calculation of the electrical field with the influence of the resin non-linearity of the specific ohmic conductivity

$$E = kU_o / (R_o^k + R_i^k) / R_i^k$$

where;

- $U_o \Rightarrow$ voltage between the screen and inside round wire
- $R_i \Rightarrow$ radius of the inside round wire
- $R_o \Rightarrow$ inside radius of the screen
- $A \Rightarrow$ constant
- $E \Rightarrow$ electrical field
- $n \Rightarrow$ factor of resin non-linearity : $2 < n < 4$, $k = n / (1+n)$

Example 3

The distance between the inside corner of our secondary winding to the core is 75mil = 0.19cm.

The wire radius is (6.7/2 mil = 0.0085cm.

$U_o = 10\text{kV}$

1. For the configuration corner-plate the value of the gradient of the magnetic field is:

$$G = 1.12U_o/3/R/(Rd^2)^{0.333}$$

$$G = 1.12 \times 10 / 3 / 0.0085 / 0.0085 / 0.19^2)^{0.333} = 6494 \text{ kV/cm}^2$$

2. Using:

$$U_o/R_i^2/\ln(2(R_o)/R_i) = 6494$$

and

$$R_o = R_i + d$$

$$\text{follows: } R_i = 0.023\text{cm}, R_o = 0.023 + 0.19 = 0.213\text{cm}$$

3. Select the resin with $n = 2$ or better ($n > 2$); $k = n/(1+n) = 2/3 = 0.666$

4. And finally the max. electrical field

$$E = 0.666 \times 10 / 0.023^{0.666} / (0.213^{0.666} - 0.023^{0.666}) = 300 \text{ kV/cm}$$

If you get any problem with this result you need to increase the thickness of the tube and/or the wire size

Topic3 / Design1

Designing mixed operation mode transformer, 230V/115V, 10A in autotransformer and 230V/115V, 10A galvanic separated connection

Input parameters

Input	Voltage	230V, +-10%, 50/60Hz, sine wave
	Wire	Cu, round, single insulated
Output	Nominal output voltage	115V, in autotransformer connection 115V, galvanic separated connection
	Nominal output current	10A, in autotransformer connection 10A, galvanic separated connection
	Wire	Cu, round, single insulated
Core	Steel	M19, alternate stacking, not annealed
Bobbin	Type	Single section
Design	Insulation class	B, max. operating temperature 120C,
	Ambient temperature	40C

Modifying the wire size from thermal point of view

Due to the fact that the program supports only the full load operation mode we need to compare the currents in both, full load and partial load operation mode (disconnected one of both 10A loads) and modify the wire size by hand in the segment Uoat-0.

In the full load operation mode the current I_x has amount of 0.348A (view 3. design page). If you disconnect the load of the galvanic separated winding the amount of the current I_x changes to 4.188A and the temperature rise from 60K to 112K (view design page 4)

Changing the wire size in the segment Uoat-0 from AWG 26 to AWG 20.5 the temperature rise can be set back to the amount of approx. 50K (view the last 2 design pages)

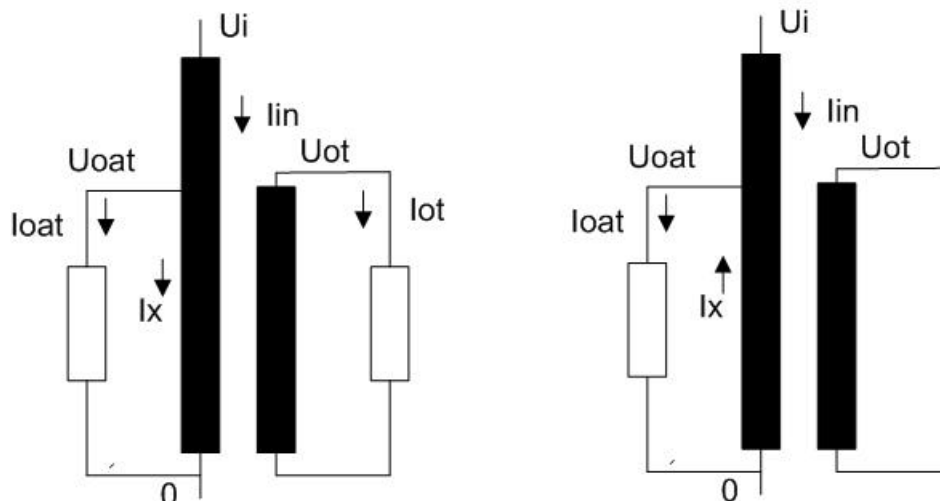

Design page 1

08-07-2008/18:07:31/14.43		Input and Circuit		Page 1	
PRIMARY U(U) I(A) Circuit--:1 115. 10. Overvlt*:1.00 230. Wire :0.0 . I/L. mil:0. . I/E. mil:5. . Formfac.:1.11 . Fre.Hz:50 . dI/Io :100 .		SECOND. 1--- 2--- 3--- 4--- 5--- 6--- 7--- 8--- Circuit--:11 Volta. U:115. Curre. A:10. Wire :0 I/L mil:0.0 I/E mil:0.0			
Regulat. %:50.0	Steel -:22	Cooling *:1.00	Bobbin -:1		
Udiode U:0.8	Induction T:1.30	Force ft/s:0.00	P/S-Order -:1		
dUdiode U:.1	Remanence *:0.35	Bracket -:1	Rac/Rdc *:1.05		
Ripple %:5.	W/kg *:1.00	Radiator -:0	Space *:0.95		
Tmp. Amb. °C:40	UAr/kg *:1.00	Chassis -:1.00	Vertical -:1		
Tmp. rise °K:60	Gap *:1.00	Channel in:0.00	Horizontal -:1		
Time 1 Min:30.0	Annealed -:0	Cu-Surface*:1.00	Impregnat. -:2		
Load 1 *:1.0	Stacking *:1.00	Rth-uarni.*:1.00	Spread %:0		
Time 2 Min:30.0	Hole -:1	Rth-comp. *:1.00	Selection -:0		
Load 2 *:1.0	Assembly -:1	Case -:0	Criterion -:0		
CIRCUIT:					
230. U	A			U	
115. U	10. A			A	
				U	
				A	
				U	
				A	
				U	
				A	
				U	
				A	
				U	
				A	

Design page 2

08-07-2008/18:07:31 CORE / BOBBIN / STEEL / CASE													Page 2																																																																																																																																																																																																																																																																															
<p>Name : 1XEI 200/(2) R /EI 2HW/(2) Steel : M19 Gauge 24 / 0.0250"</p>															Weight lb: 19.52																																																																																																																																																																																																																																																																													
<p> \uparrow F \uparrow B \uparrow A \uparrow B \uparrow F \uparrow \uparrow D \uparrow T E \uparrow C \uparrow E L </p>															Gap total in: 0.000																																																																																																																																																																																																																																																																													
<p> \uparrow a2 \uparrow \uparrow d2 \uparrow T l L \uparrow a1 \uparrow \uparrow d1 \uparrow </p>															A-Limb in: 2.00																																																																																																																																																																																																																																																																													
<p> a1 cm: 2.18 a2 cm: 4.94 d1 cm: 2.18 d2 cm: 4.94 l cm: 3.60 lp cm: ls cm: Margin cm: 0.07 </p>															B-Width in: 1.50																																																																																																																																																																																																																																																																													
<p> X- Length 1 in: Y- Width 1 in: Z- Height 1 in: x- Length 2 in: y- Width 2 in: z- Height 2 in: w- Thickness in: Material : Potted : </p>															C-Height in: 3.74																																																																																																																																																																																																																																																																													
<p> Radiator Fin : 0 Radiator Chan. : 0 </p>															D-Stack in: 2.02																																																																																																																																																																																																																																																																													
<p> E-Yoke 1 in: 1.25 F-Yoke 2 in: 1.25 G-Hole in: 0.31 </p>															E-Yoke 1 in: 1.25																																																																																																																																																																																																																																																																													
<p> F-Yoke 2 in: 1.25 G-Hole in: 0.31 </p>															F-Yoke 2 in: 1.25																																																																																																																																																																																																																																																																													
<p> Radiator Fin : 0 Radiator Chan. : 0 </p>															G-Hole in: 0.31																																																																																																																																																																																																																																																																													
<p> a1 cm: 2.18 a2 cm: 4.94 d1 cm: 2.18 d2 cm: 4.94 l cm: 3.60 lp cm: ls cm: Margin cm: 0.07 </p>															Radiator Fin : 0																																																																																																																																																																																																																																																																													
<p> Radiator Chan. : 0 </p>															Radiator Chan. : 0																																																																																																																																																																																																																																																																													
<table border="1"> <thead> <tr> <th></th> <th>Typ</th> <th>Windun</th> <th>MTI</th> <th>DN</th> <th>DN</th> <th>Par</th> <th>D/φ mil</th> <th>B/φ mil</th> <th>W/L</th> <th>L</th> <th>I/L mil</th> <th>I/E mil</th> <th>Weight lb</th> <th>RWH %</th> </tr> </thead> <tbody> <tr> <td>1</td> <td>1</td> <td>154.8</td> <td>C00</td> <td>26.0</td> <td>26.0</td> <td>1</td> <td>15.9</td> <td>15.9</td> <td>205</td> <td>.76</td> <td>.</td> <td>5.</td> <td>.086</td> <td>1.3</td> </tr> <tr> <td>2</td> <td>1</td> <td>308.1</td> <td>C00</td> <td>12.5</td> <td>12.5</td> <td>1</td> <td>76.3</td> <td>76.3</td> <td>44</td> <td>3.5</td> <td>.</td> <td>5.</td> <td>2.206</td> <td>24.</td> </tr> <tr> <td>3</td> <td></td> <td></td> <td></td> <td></td> <td></td> <td></td> <td></td> <td></td> <td></td> <td></td> <td></td> <td></td> <td></td> <td></td> </tr> <tr> <td>4</td> <td></td> <td></td> <td></td> <td></td> <td></td> <td></td> <td></td> <td></td> <td></td> <td></td> <td></td> <td></td> <td></td> <td></td> </tr> <tr> <td>5</td> <td></td> <td></td> <td></td> <td></td> <td></td> <td></td> <td></td> <td></td> <td></td> <td></td> <td></td> <td></td> <td></td> <td></td> </tr> <tr> <td>6</td> <td></td> <td></td> <td></td> <td></td> <td></td> <td></td> <td></td> <td></td> <td></td> <td></td> <td></td> <td></td> <td></td> <td></td> </tr> <tr> <td>7</td> <td></td> <td></td> <td></td> <td></td> <td></td> <td></td> <td></td> <td></td> <td></td> <td></td> <td></td> <td></td> <td></td> <td></td> </tr> <tr> <td>8</td> <td></td> <td></td> <td></td> <td></td> <td></td> <td></td> <td></td> <td></td> <td></td> <td></td> <td></td> <td></td> <td></td> <td></td> </tr> <tr> <td>1</td> <td>11</td> <td>161.6</td> <td>C00</td> <td>11.0</td> <td>11.0</td> <td>1</td> <td>90.7</td> <td>90.7</td> <td>37</td> <td>4.3</td> <td>.</td> <td>.</td> <td>4.179</td> <td>36.</td> </tr> <tr> <td>2</td> <td></td> <td></td> <td></td> <td></td> <td></td> <td></td> <td></td> <td></td> <td></td> <td></td> <td></td> <td></td> <td></td> <td></td> </tr> <tr> <td>3</td> <td></td> <td></td> <td></td> <td></td> <td></td> <td></td> <td></td> <td></td> <td></td> <td></td> <td></td> <td></td> <td></td> <td></td> </tr> <tr> <td>4</td> <td></td> <td></td> <td></td> <td></td> <td></td> <td></td> <td></td> <td></td> <td></td> <td></td> <td></td> <td></td> <td></td> <td></td> </tr> <tr> <td>5</td> <td></td> <td></td> <td></td> <td></td> <td></td> <td></td> <td></td> <td></td> <td></td> <td></td> <td></td> <td></td> <td></td> <td></td> </tr> <tr> <td>6</td> <td></td> <td></td> <td></td> <td></td> <td></td> <td></td> <td></td> <td></td> <td></td> <td></td> <td></td> <td></td> <td></td> <td></td> </tr> <tr> <td>7</td> <td></td> <td></td> <td></td> <td></td> <td></td> <td></td> <td></td> <td></td> <td></td> <td></td> <td></td> <td></td> <td></td> <td></td> </tr> <tr> <td>8</td> <td></td> <td></td> <td></td> <td></td> <td></td> <td></td> <td></td> <td></td> <td></td> <td></td> <td></td> <td></td> <td></td> <td></td> </tr> <tr> <td colspan="13">TOTAL</td> <td colspan="2">6.471 63.</td> </tr> </tbody> </table>																Typ	Windun	MTI	DN	DN	Par	D/φ mil	B/φ mil	W/L	L	I/L mil	I/E mil	Weight lb	RWH %	1	1	154.8	C00	26.0	26.0	1	15.9	15.9	205	.76	.	5.	.086	1.3	2	1	308.1	C00	12.5	12.5	1	76.3	76.3	44	3.5	.	5.	2.206	24.	3															4															5															6															7															8															1	11	161.6	C00	11.0	11.0	1	90.7	90.7	37	4.3	.	.	4.179	36.	2															3															4															5															6															7															8															TOTAL													6.471 63.	
	Typ	Windun	MTI	DN	DN	Par	D/φ mil	B/φ mil	W/L	L	I/L mil	I/E mil	Weight lb	RWH %																																																																																																																																																																																																																																																																														
1	1	154.8	C00	26.0	26.0	1	15.9	15.9	205	.76	.	5.	.086	1.3																																																																																																																																																																																																																																																																														
2	1	308.1	C00	12.5	12.5	1	76.3	76.3	44	3.5	.	5.	2.206	24.																																																																																																																																																																																																																																																																														
3																																																																																																																																																																																																																																																																																												
4																																																																																																																																																																																																																																																																																												
5																																																																																																																																																																																																																																																																																												
6																																																																																																																																																																																																																																																																																												
7																																																																																																																																																																																																																																																																																												
8																																																																																																																																																																																																																																																																																												
1	11	161.6	C00	11.0	11.0	1	90.7	90.7	37	4.3	.	.	4.179	36.																																																																																																																																																																																																																																																																														
2																																																																																																																																																																																																																																																																																												
3																																																																																																																																																																																																																																																																																												
4																																																																																																																																																																																																																																																																																												
5																																																																																																																																																																																																																																																																																												
6																																																																																																																																																																																																																																																																																												
7																																																																																																																																																																																																																																																																																												
8																																																																																																																																																																																																																																																																																												
TOTAL													6.471 63.																																																																																																																																																																																																																																																																															

Design page 3

08-07-2008/18:07:31	General Data	Page 3
<p>NOMINAL OPERATION at Temperature °C 100.3 and Overvoltage 1.00</p> <p>Output Power on Load W:2299. Output Power of Transform. W:2299. Cu Losses W:61.88 Fe-Losses active W:14.29 Short-Circuit-Volt. cold %:2.03 Regulation %:2.68 Instantaneous pow. .5/95& W:950. Efficiency of Transformer %:96.79 dT Fe average Surface °K:48. dT primary °K:60.9 dT Case aver. Surface °K:.. dT secondary °K:59.8</p>		
<p>0.505Ω 0.03 Ω 224.8Ω 0.075Ω 0.154Ω 224. Ω -0.46 ° 2.27 % 0.14 % 97.7 % 0.34 % 0.69 % 97.39 % 22.26 Ω 230. Ω 100 % 3536 Ω 15882 % 33771 Ω 10993 % 2447 Ω 100 % 21.81 Ω 10.33 A .943 nF . mH 21.81 Ω 10.26 A 100.6 % 1.3 T 100 %</p>		
<p>DUTY CYCLE OPERATION at Amb. Temperature °C 40. and Overvoltage 1.00</p> <p>dT Fe average Surface °K:48. dT primary °K:60.9 dT Gehäuse av. Surface °K:.. dT secondary °K:59.8</p>		
<p>NO LOAD OPERATION at Amb. Temperature °C 40. and Overvoltage 1.00</p> <p>Losses active W:14.33 Losses reactive UAr:22.78 Current factor %:1.13 Induction T:1.328 dT Fe average Surface °K:13.2 dT primary °K:11.7 dT Gehäuse av. Surface °K:.. Resonance frequency kHz:1.9</p>		
<p>SHORT-CIRCUIT OPERATION at Amb. Temperature °C 40. and Overvoltage 1.00</p> <p>Losses active W:10843 Losses reactive UAr:44587 Current factor cold %:4933. Induction T:1.206 dT Fe average Surface °K:3264. dT primary °K:4278. dT Gehäuse av. Surface °K:.. dT secondary °K:3943.</p>		
<p>PRIMARY (Tap:2) 1---- 2---- 3---- 4---- 5---- 6---- 7---- 8----</p> <p>Voltage Input/Output U:115. 230. Out. Voltage no load U:115.7 Current Input/Output A:10. 10.33 Load on output Ω:11.5 Power factor of load :1.000 Current in segment A:0.348 10.33 Current density A/in²:1752. 2259. Icc-Current cold A:530.6 509.7 Io -Current A: 0.117 Inrush Current peak ^A: 47.65 Inrush Current rms A: 18.71 Cu-Losses W: 33.2 Resistance cold Ω:4.709 4.938 Reactance Ω:.091 .0893 Eddy-Current Factor :1. 1.</p>		
<p>SECONDARY 1---- 2---- 3---- 4---- 5---- 6---- 7---- 8----</p> <p>Output Voltage U:114.9 Output Current A:10. Out. Voltage no load U:120.4 Sec. Voltage U:114.9 Sec. Current A:10. Current density A/in²:1547. Sec. Voltage cold U:116.2 Load on output Ω:11.5 Power factor of load :1.000 Icc cold A:463.7 Cu-Losses warm W:28.71 Resistance cold Ω:.2168 Reactance Ω:.0992 Eddy-Current Factor :1. Capacitor mF:..</p>		

Design page 4

08-07-2008/18:14:58	General Data	Page 3
<p>NOMINAL OPERATION at Temperature °C 147.4 and Overvoltage 1.00</p> <p>Output Power on Load W:884.6 Output Power of Transform. W:884.6 Cu Losses W:133.3 Fe-Losses active W:16.28 Short-Circuit-Volt. cold %:0.88 Regulation %:15.23 Instantaneous pow. .5/958 W:1671. Efficiency of Transformer %:85.53 dT Fe average Surface °K:81.5 dT primary °K:112.8 dT Case aver. Surface °K:. dT secondary °K:102.1</p>		
<p>Diagram parameters: -6.26Ω -0.85Ω 258.5U 13.27Ω 1.053Ω 199.6 U -0.65 ° -12.2% -1.67% 112.4% 26.02% 2.06 % 86.78 % 51.01 Ω 230. U 4103 Ω 33769 Ω 920 Ω 45.03 Ω 100 % 8043. % .943 nF . 1803. % 45.03 Ω 4.509 A 1.495T 100 % 4.432 A</p>		
<p>DUTY CYCLE OPERATION at Amb. Temperature °C 40. and Overvoltage 1.00</p> <p>dT Fe average Surface °K:81.5 dT primary °K:112.8 dT Gehäuse av. Surface °K:. dT secondary °K:102.1</p>		
<p>NO LOAD OPERATION at Amb. Temperature °C 40. and Overvoltage 1.00</p> <p>Losses active W:14.33 Losses reactive UAr:22.77 Current factor %:2.59 Induction T:1.328 dT Fe average Surface °K:13.2 dT primary °K:11.7 dT Gehäuse av. Surface °K:. Resonance frequency kHz:3.</p>		
<p>SHORT-CIRCUIT OPERATION at Amb. Temperature °C 40. and Overvoltage 1.00</p> <p>Losses active W:10846 Losses reactive UAr:44602 Current factor cold %:11309 Induction T:1.206 dT Fe average Surface °K:3266. dT primary °K:4280. dT Gehäuse av. Surface °K:. dT secondary °K:3945.</p>		
<p>PRIMARY (Tap:2) 1---- 2---- 3---- 4---- 5---- 6---- 7---- 8----</p> <p>Voltage Input/Output U:99.8 230. Out. Voltage no load U:115.7 Current Input/Output A:8.679 4.509 Load on output Ω:11.5 Power factor of load :1.000 Current in segment A:4.188 4.509 Current density A/in²:21077 986.2 Icc-Current cold A:530.7 509.9 Io -Current A: 0.117 Inrush Current peak ^A: 49.01 Inrush Current rms A: 19.53 Cu-Losses W: 133.3 Resistance cold Ω:4.710 4.939 Reactance Ω:.0911 .0893 Eddy-Current Factor :1. 1.</p>		
<p>SECONDARY 1---- 2---- 3---- 4---- 5---- 6---- 7---- 8----</p> <p>Output Voltage U:135.5 Output Current A:0.136 Out. Voltage no load U:120.4 Sec. Voltage U:135.5 Sec. Current A:0.136 Current density A/in²:20.99 Sec. Voltage cold U:130.9 Load on output Ω:999. Power factor of load :1.000 Icc cold A:463.6 Cu-Losses warm W:.006 Resistance cold Ω:.2168 Reactance Ω:.0992 Eddy-Current Factor :1. Capacitor mF:.</p>		

Design page 5

08-07-2008/18:16:47 CORE / BOBBIN / STEEL / CASE													Page 2	
<p>Name : 1XEI 200/(2) R /EI 2HW/(2) Steel : M19 Gauge 24 / 0.0250" /25.59</p>														
<p> F B A B F D </p>														
T											Weight	lb:19.52		
E											Gap total	in:0.000		
											A-Limb	in:2.00		
C											B-Width	in:1.50		
											C-Height	in:3.74		
E											D-Stack	in:2.02		
											E-Yoke 1	in:1.25		
E											F-Yoke 2	in:1.25		
											G-Hole	in:0.31		
l											Radiator Fin	:0		
											Radiator Chan.	:0		
											a1	cm:2.18		
T											a2	cm:4.94		
											d1	cm 2.18		
											d2	cm 4.94		
											l	cm:3.60		
											lp	cm:		
											ls	cm:		
											Margin	cm:0.07		
<p>X- Length 1 in: Y- Width 1 in: Z- Height 1 in: x- Length 2 in: y- Width 2 in: z- Height 2 in: w- Thickness in: Material : Potted :</p>														
	Typ	Windun	MTI	DN	DN	Par	D/φ mil	B/φ mil	W/L	L	I/L mil	I/E mil	Weight lb	RWH %
1	1	154.8	C00	20.5	20.5	1	30.2	30.2	111	1.4	.	5.	.315	4.8
2	1	308.1	C00	12.5	12.5	1	76.3	76.3	44	3.5	.	5.	2.273	24.
3														
4														
5														
6														
7														
8														
1	11	161.6	C00	11.0	11.0	1	90.7	90.7	37	4.3	.	.	4.104	36.
2														
3														
4														
5														
6														
7														
8														
TOTAL													6.693	60.

Design page 6

08-07-2008/18:16:47	General Data	Page 3
<p>NOMINAL OPERATION at Temperature °C 88.4 and Overvoltage 1.00</p> <p>Output Power on Load W:1083. Output Power of Transform. W:1083.</p> <p>Cu Losses W:44.65 Fe-Losses active W:14.22</p> <p>Short-Circuit-Volt. cold %:0.94 Regulation %:4.15</p> <p>Instantaneous pow. .5/958 W:3466. Efficiency of Transformer %:94.85</p> <p>dT Fe average Surface °K:40.3 dT primary °K:50.4</p> <p>dT Case aver. Surface °K:. dT secondary °K:46.4</p>		
<p>Diagram parameters: -1.29Ω -0.06Ω 236.4V 3.179Ω 0.242Ω 220.8 V -0.25 ° -2.79% -0.15% 102.8% 6.87 % 0.52 % 96.01 % 46.28 Ω 44.99 Ω 230. V 3932 Ω 42347 Ω 2152 Ω 100 % 8496. % .752 nF .4650. % 4.97 A 4.908 A 101.3 % 1.367T 100 %</p>		
<p>DUTY CYCLE OPERATION at Amb. Temperature °C 40. and Overvoltage 1.00</p> <p>dT Fe average Surface °K:40.3 dT primary °K:50.4</p> <p>dT Gehäuse av. Surface °K:. dT secondary °K:46.4</p>		
<p>NO LOAD OPERATION at Amb. Temperature °C 40. and Overvoltage 1.00</p> <p>Losses active W:14.28 Losses reactive UAr:22.45</p> <p>Current factor %:2.33 Induction T:1.329</p> <p>dT Fe average Surface °K:13.2 dT primary °K:11.7</p> <p>dT Gehäuse av. Surface °K:. Resonance frequency kHz:2.2</p>		
<p>SHORT-CIRCUIT OPERATION at Amb. Temperature °C 40. and Overvoltage 1.00</p> <p>Losses active W:11360 Losses reactive UAr:43744</p> <p>Current factor cold %:10650 Induction T:1.111</p> <p>dT Fe average Surface °K:3334. dT primary °K:4413.</p> <p>dT Gehäuse av. Surface °K:. dT secondary °K:3987.</p>		
<p>PRIMARY (Tap:2) 1---- 2---- 3---- 4---- 5---- 6---- 7---- 8----</p> <p>Voltage Input/Output U:110.8 230.</p> <p>Out. Voltage no load U:115.6</p> <p>Current Input/Output A:9.639 4.97</p> <p>Load on output Ω:11.5</p> <p>Power factor of load :1.000</p> <p>Current in segment A:4.671 4.97</p> <p>Current density A/in²:6521. 1087.</p> <p>Icc-Current cold A:599.5 529.3</p> <p>Io -Current A: 0.116</p> <p>Inrush Current peak ^A: 86.87</p> <p>Inrush Current rms A: 39.01</p> <p>Cu-Losses W: 44.6</p> <p>Resistance cold Ω:1.329 1.565</p> <p>Reactance Ω:.0898 .0881</p> <p>Eddy-Current Factor :1. 1.</p>		
<p>SECONDARY 1---- 2---- 3---- 4---- 5---- 6---- 7---- 8----</p> <p>Output Voltage U:123.9</p> <p>Output Current A:0.124</p> <p>Out. Voltage no load U:120.5</p> <p>Sec. Voltage U:123.9</p> <p>Sec. Current A:0.124</p> <p>Current density A/in²:19.2</p> <p>Sec. Voltage cold U:123.3</p> <p>Load on output Ω:999.</p> <p>Power factor of load :1.000</p> <p>Icc cold A:435.6</p> <p>Cu-Losses warm W:.004</p> <p>Resistance cold Ω:.2129</p> <p>Reactance Ω:.0979</p> <p>Eddy-Current Factor :1.</p> <p>Capacitor mF:.</p>		

Topic2 / Design1

Designing three phase autotransformer, for 3x400V/3x380V, 10kVA output power and 25% one phase unsymmetrical load

Input parameters

Input	Voltage	3 x 400V, +-10%, 50Hz, sine wave
	Wire	Cu, round, single insulated
	Layer insulation	No
	Final insulation	No
Output	Nominal output voltage	3 x 380V, star connection with 3 x 220V between phases and neutral line
	Nominal output current	3 x 15.15A and 1 x 3.78A UNSYMMETRICAL load
	Wire	Cu, round, single insulated
	Layer insulation	No
Core	Steel	M45, alternate stacking, not annealed
	Assembly	Gaped with 10 mil between E and I for limiting the magnetic flux of the unsymmetrical current.
Bobbin	Type	Single section
Design	Insulation class	B, max. operating temperature 120C,
	Ambient temperature	40C

Modifying the wire size from thermal point of view

Due to the fact that the program supports only the three phase symmetrical operation mode we need to compare the currents in both symmetrical and unsymmetrical operation mode, and modify the wire size by hand using the following pictures:

In the unsymmetrical operation mode the current between the neutral and U_o tap is $I_{un}/3 = 3.78/3 = 1.26A$. Between U_i and U_o taps the max current is $2I_{un}/3 = 2.52A$

In the symmetrical operation mode the current between the neutral and U_o tap is $(1-U_o/U_i)I_n = 0.635A$ (view the segment currents on the last page). Between U_i and U_o taps the max current is $I_i = 14.6A$.

If we compare the currents between the neutral and the U_o tap then we have to follow this procedure in order to design our autotransformer from thermal point of view properly:

1. Run the program in the symmetrical operation mode and select a bigger core in order to get the build approx. 40%

2. Increase the wire cross section of the winding between the neutral and the U_0 tap approx. by the factor $(1.26/0.635)^2 = 3.93$

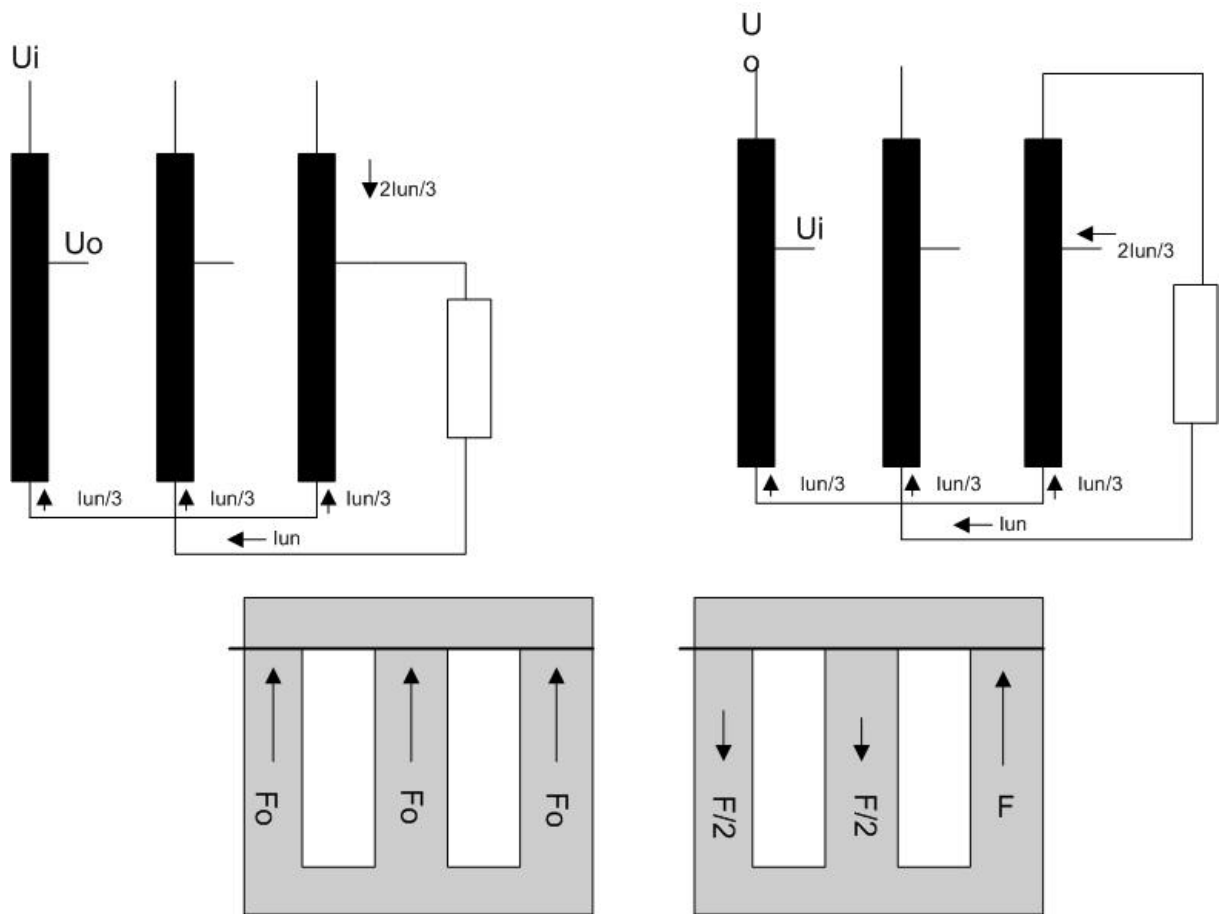

Calculating the induction during the unsymmetrical operation mode

Finally we need to check the size of the inductions B_0 and B of the magnetic fluxes F_0 and F .

1. The magnetic fluxes F_0 are equal by size and phase. They flow through the legs and close their loops outside the core. They are normally very small and can be neglected.
2. Note that the ampere-turns of the no-load current $W_i \times I_0 = 845 \times 0.268 = 226$ excites over one leg the main induction of 1.3T (set on the input screen).
3. The magnetic flux F is driven by ampere-turns (on the leg with the unsymmetrical load) of the unsymmetrical current are:

$$(2/3) \times (W_i - W_0) \times I_{un} = 0.666 \times (845 - 812) \times 3.78 = 83$$
 Due to the fact that the phase delay between the main flux (driven by input voltage) and the flux F (driven by unsymmetrical current on the leg with the unsymmetrical load) is 90 degrees the max. induction in the leg during the unsymmetrical operation mode will be:

$$B_{max} = 1.3 \times (1 + (83/226)^2)^{0.5} = 1.3 \times 1.06 = 1.385T$$
4. In order to get a very low influence of the unsymmetrical current the core has to be gaped by 10mil between the E and I part.

Name	:3 X EI 3P120/(1_1/5)
Steel	-:M45 Gauge 24 / 0.0250"
Number of Sections	-:1
max.Cu-Fill Factor	%:88.9
max. parallel Wires	:1
Induction on Load	T:1.374
Max. Induction	T:1.357
Max.Cu-Temp.rise on load	°K:50.8
Max.Cu-Temp.rise no-load	°K:18.3
Regulation	%:4
I [^] Inrush/I [^] nom-Factor	*:9
Input Current No-Load	%:1.8

PRIMARY	U(V) I(A)	SECOND.	1---	2---	3---	4---	5---	6---	7---	8---
Circuit-:1	220. 15.2	Circuit-:								
Overvlt*:1.00	230.	Volta. U:								
Wire :0.0	.	Curre. A:								
I/L. mil:0.	.	Wire :								
I/E. mil:0.	.	I/L mil:								
Formfac.:1.11	.	I/E mil:								
Fre.Hz:50	.									
dI/Io :100	.									

Regulat. %:7.0	Steel -:17	Cooling *:1.00	Bobbin -:1
Udiode U:0.8	Induction T:1.37	Force ft/s:0.00	P/S-Order -:2
dUdiode U:.1	Remanence *:0.35	Bracket -:1	Rac/Rdc *:1.05
Ripple %:5.	W/kg *:1.00	Radiator -:0	Space *:2.00
Tmp. Amb. °C:40	UAr/kg *:1.00	Chassis -:1.00	Vertical -:1
Tmp.rise °K:60	Gap *:10.00	Channel in:0.00	Horizontal -:1
Time 1 Min:30.0	Annealed -:0	Cu-Surface*:1.00	Impregnat. -:2
Load 1 *:1.0	Stacking *:1.00	Rth-varni. *:1.00	Spread %:0
Time 2 Min:30.0	Hole -:1	Rth-comp. *:1.00	Selection -:2
Load 2 *:1.0	Assembly -:2	Case -:0	Criterion -:2

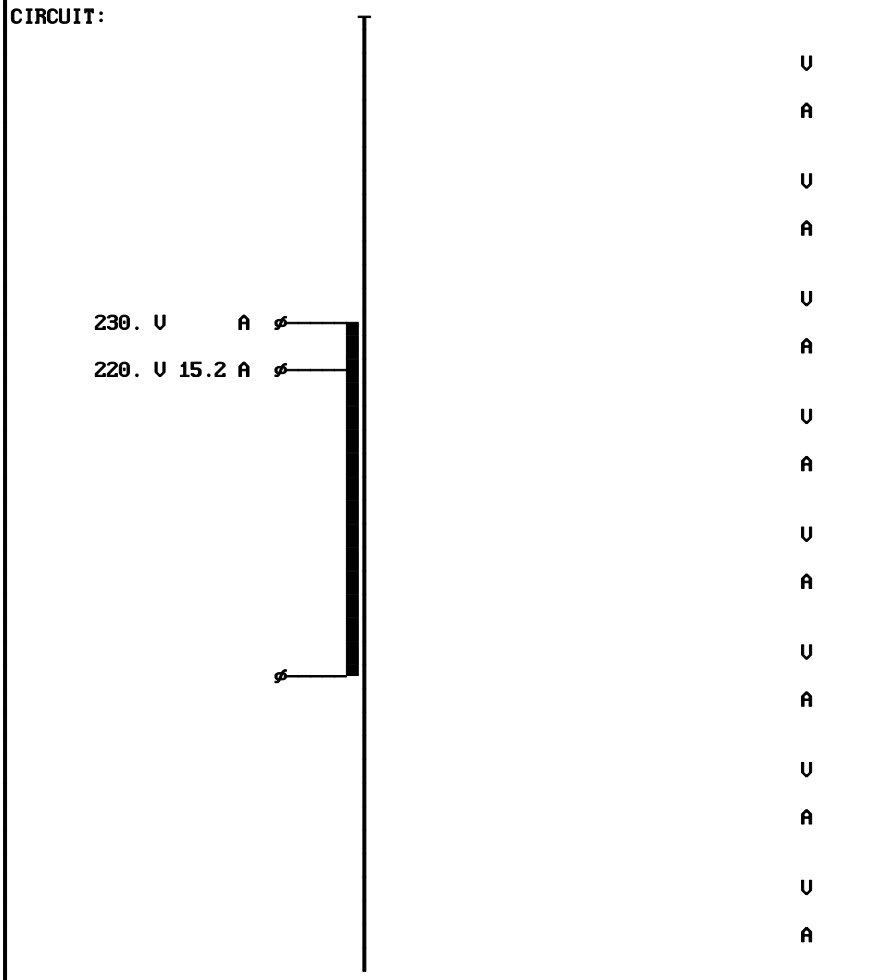

Name :3XEI 3P120/(1_1/5)

Steel :M45 Gauge 24 / 0.0250"

/25.59

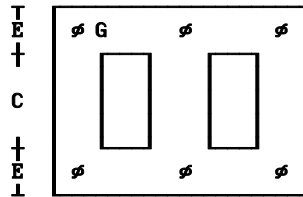
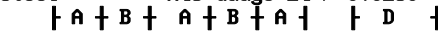

with three bobbins

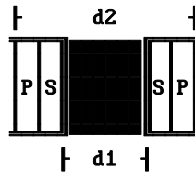
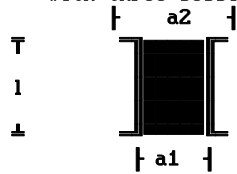

Weight	lb:8.27
Gap total	in:0.000
A-Limb	in:1.20
B-Width	in:1.20
C-Height	in:3.00
D-Stack	in:1.20
E-Yoke 1	in:1.20
F-Yoke 2	in:1.20
G-Hole	in:0.326
Radiator Fin	:0
Radiator Chan.	:0
a1	cm:1.36
a2	cm:2.35
d1	cm 1.36
d2	cm 2.35
l	cm:2.88
lp	cm:
ls	cm:
Margin	cm:0.06

X- Length 1 in:
 Y- Width 1 in:
 Z- Height 1 in:
 x- Length 2 in:
 y- Width 2 in:
 z- Height 2 in:
 w- Thickness in:
 Material :
 Potted :

	Typ	Windun	MTI	DN	DN	Par	D/φ mil	B/φ mil	W/L	L	I/L mil	I/E mil	Weight lb	RWH %
1	1	812.4	C00	20.0	20.0	1	32.	32.	83	9.7	.	.	1.351	70.
2	1	845.6	C00	12.0	12.0	1	80.8	80.8	33	1.0	.	.	.444	36.
3														
4														
5														
6														
7														
8														
1														
2														
3														
4														
5														
6														
7														
8														
TOTAL													5.387	88.

NOMINAL OPERATION at Temperature °C 90.4 and Overvoltage 1.00
 Output Power on Load W:10051 Output Power of Transform. W:10051
 Cu Losses W:12.41 Fe-Losses active W:5.96
 Short-Circuit-Volt. cold %:0.28 Regulation %:1.35
 Instantaneous pow. .5/958 W:80606 Efficiency of Transformer %:99.45
 dT Fe average Surface °K:47.1 dT primary °K:50.9
 dT Case aver. Surface °K:. dT secondary °K:

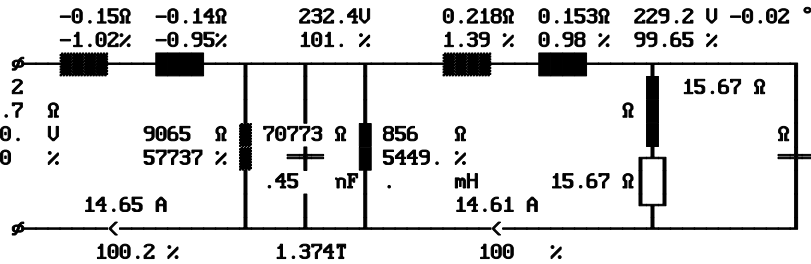

DUTY CYCLE OPERATION at Amb. Temperature °C 40. and Overvoltage 1.00
 dT Fe average Surface °K:47.1 dT primary °K:50.8
 dT Gehäuse av. Surface °K:. dT secondary °K:

NO LOAD OPERATION at Amb. Temperature °C 40. and Overvoltage 1.00
 Losses active W:6.19 Losses reactive UAr:61.27
 Current factor %:1.83 Induction T:1.357
 dT Fe average Surface °K:20.4 dT primary °K:18.3
 dT Gehäuse av. Surface °K:. Resonance frequency kHz:4.5

SHORT-CIRCUIT OPERATION at Amb. Temperature °C 40. and Overvoltage 1.00
 Losses active W:11903 Losses reactive UAr:90161
 Current factor cold %:35427 Induction T:1.36
 dT Fe average Surface °K:7461. dT primary °K:8768.
 dT Gehäuse av. Surface °K:. dT secondary °K:

PRIMARY (Tap:2) 1---- 2---- 3---- 4---- 5---- 6---- 7---- 8----
 Voltage Input/Output U:220.2 230.
 Out. Voltage no load U:221.
 Current Input/Output A:15.21 14.65
 Load on output Ω :14.47
 Power factor of load :1.000
 Current in segment A:0.631 14.65
 Current density A/in²:787.1 2856.
 Icc-Current cold A:5401. 5190.
 Io -Current A: 0.268
 Inrush Current peak ^A: 19.56
 Inrush Current rms A: 9.02
 Cu-Losses W: 12.4
 Resistance cold Ω :4.563 4.600
 Reactance Ω :.9902 .0017
 Eddy-Current Factor :1. 1.

SECONDARY 1---- 2---- 3---- 4---- 5---- 6---- 7---- 8----
 Output Voltage U:
 Output Current A:
 Out. Voltage no load U:
 Sec. Voltage U:
 Sec. Current A:
 Current density A/in²:
 Sec. Voltage cold U:
 Load on output Ω :
 Power factor of load :
 Icc cold A:
 Cu-Losses warm W:
 Resistance cold Ω :
 Reactance Ω :
 Eddy-Current Factor :
 Capacitor mF:

Topic: Inrush Current / Design1

Designing three phase, low inrush current universal autotransformer for 3x208V/120V, 50/60Hz, 9A

Input parameters

Input	Voltage	3 x 380/400/480/690V, +-6%, star connection, 50/60Hz, sine wave
	Wire	Cu, round, single insulated
	Layer insulation	No
	Final insulation	Yes
Output	Nominal output voltage	3 x 208, star connection with 3 x 120V between phases and neutral line
	Nominal output current	3 x 9A
	Wire	Cu, round, single insulated
	Layer insulation	No
Core	Steel	M45, not annealed
	Assembly	Gaped with 5mil between E and I for limiting the remanence in the core.
Bobbin	Type	Single section
Design	Insulation class	B, max. operating temperature 120C,
	Ambient temperature	40C

About “low” inrush current

Note that you can not prescribe the value of the inrush current. But using the following rules you can easily limit it under the value you need:

1. If you use cold rolled or grain oriented steel set the induction between 0.9 and 1.3.
2. Use high temperature rise to increase the resistance of windings.
3. Unfortunately the remanence cannot be calculated in an alternated stacked core and vary between 20% and 70% of the operating induction. If you want to get a small and enough accurate amount of the calculated inrush current then use the gaped core assembly to reduce the remanence. Normally 3-5mil gap is big enough to reduce the remanence less than 5% of the operating induction and increase the accuracy of the inrush current calculation. The control parameter of the gap size is the amount of the no-load current. A good no-load current is smaller than 25% of the nominal primary current.
4. If you design a transformer set the primary outside. Reduce the primary wire cross section and increase the secondary wire cross section so that the temperature rise and the output voltage stay under the value you need. Due to the fact that the primary resistance is higher the inrush current will be smaller.

If you use cold rolled or grain oriented steel and you set the nominal operating induction at 0.8-0.9T then the inrush current will be very small and can be neglected. Normally, in order to save the material costs the used operating induction is 1.1-1.3T

If the relationship between the peak value of the inrush current and the peak value of the nominal current of an inverter is less than 8 then the transformer can be connected to the inverter and the inrush current is low enough.

If the relationship between the rms value of the inrush current within the first period and nominal value of a slow fuse current is less than 15 then the slow fuse can be used on the primary side of transformers. If you don't want to use the slow fuse you can use the calculated rms inrush current (view the last design page) during the first period and calculate I^2t . With the calculated I^2t you can select any fuse from catalogue.

#*0	DIAGNOSE	Page 0
Name	:3 X EI 3P180/(2.0)	
Steel	:-M45 Gauge 24 / 0.0250"	
Number of Sections	:-1	
max.Cu-Fill Factor	∴:87.9	
max. parallel Wires	:1	
Induction on Load	T:1.272	
Max. Induction	T:1.285	
Max.Cu-Temp.rise on load	°K:74.5	
Max.Cu-Temp.rise no-load	°K:24.2	
Regulation	∴:3.5	
$I^{\wedge}Inrush/I^{\wedge}nom$ -Factor	*:6.9	
Input Current No-Load	∴:6.5	

PRIMARY	U(V)	I(A)	SECOND.	1---	2---	3---	4---	5---	6---	7---	8---
Circuit-:	1	120.9.	Circuit-:								
Overvlt*:	1.06	220.	Volta. U:								
Wire :	0.0	230.	Curre. A:								
I/L. mil:	0.	277.	Wire :								
I/E. mil:	0.	400.	I/L mil:								
Formfac.:	1.11	.	I/E mil:								
Fre.Hz:	50	.									
dI/Io :	100	.									

Regulat. %:	50.0	Steel	-:17	Cooling	*:1.00	Bobbin	-:1
Udiode U:	0.8	Induction T:	1.27	Force ft/s:	0.00	P/S-Order	-:2
dUdiode U:	.1	Remanence	*:0.05	Bracket	-:1	Rac/Rdc	*:1.05
Ripple %:	5.	W/kg	*:1.00	Radiator	-:0	Space	*:0.95
Tmp. Amb. °C:	40	UAr/kg	*:1.00	Chassis	-:1.00	Vertical	-:1
Tmp. rise °K:	75	Gap	*:5.00	Channel in:	0.00	Horizontal	-:1
Time 1 Min:	30.0	Annealed	-:0	Cu-Surface*:	1.00	Impregnat.	-:2
Load 1	*:1.0	Stacking	*:1.00	Rth-uarni.:	*:1.00	Spread	%:0
Time 2 Min:	30.0	Hole	-:1	Rth-comp.:	*:1.50	Selection	-:2
Load 2	*:1.0	Assembly	-:2	Case	-:0	Criterion	-:0

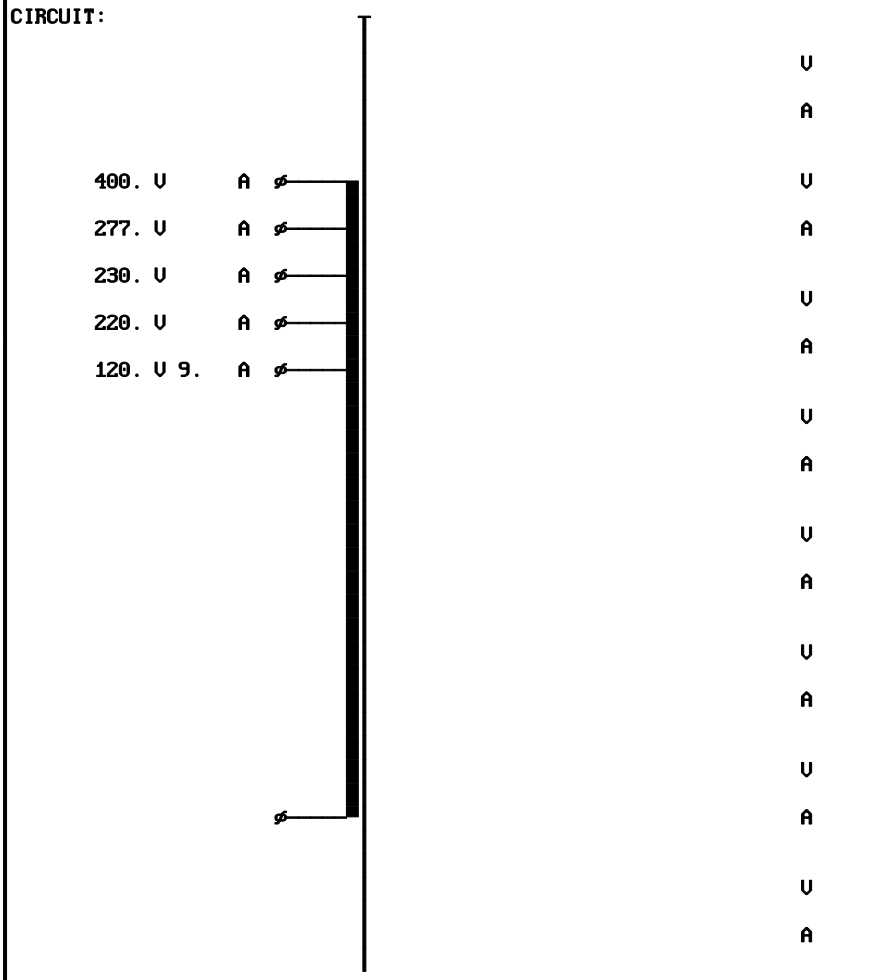

Name :3XEI 3P180/(2.0)
 Steel :M45 Gauge 24 / 0.0250"

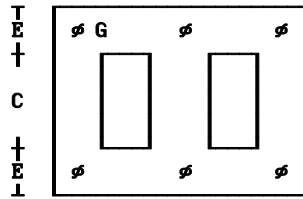
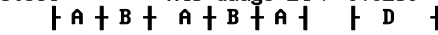

with three bobbins

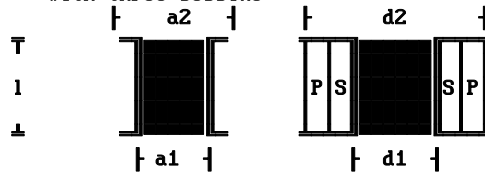

Weight	lb:30.97
Gap total	in:0.000
A-Limb	in:1.80
B-Width	in:1.80
C-Height	in:4.50
D-Stack	in:2.00
E-Yoke 1	in:1.80
F-Yoke 2	in:1.80
G-Hole	in:0.49
Radiator Fin	:0
Radiator Chan.	:0
a1	cm:2.03
a2	cm:3.53
d1	cm 2.20
d2	cm 3.76
l	cm:4.25
lp	cm:
ls	cm:
Margin	cm:0.13

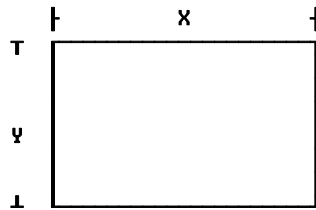

X- Length 1 in:
 Y- Width 1 in:
 Z- Height 1 in:
 x- Length 2 in:
 y- Width 2 in:
 z- Height 2 in:
 w- Thickness in:
 Material :
 Potted :

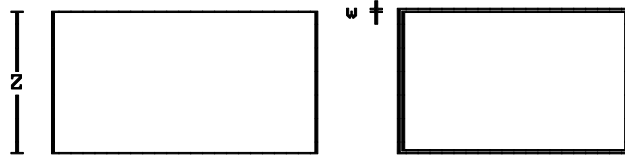

	Typ	Windun	MTI	DN	DN	Par	D/φ mil	B/φ mil	W/L	L	I/L mil	I/E mil	Weight lb	RWH %
1	1	204.7	C00	13.0	13.0	1	72.	72.	55	3.7	.	.	2.505	42.
2	1	364.6	C00	16.0	16.0	1	50.8	50.8	78	2.0	.	.	1.128	22.
3	1	377.7	C00	16.0	16.0	1	50.8	50.8	78	.17	.	.	.098	7.5
4	1	456.8	C00	16.0	16.0	1	50.8	50.8	78	1.0	.	.	.592	15.
5	1	660.2	C00	16.0	16.0	1	50.8	50.8	78	2.6	.	.	1.578	22.
6														
7														
8														
1														
2														
3														
4														
5														
6														
7														
8														
TOTAL													17.70	87.

NOMINAL OPERATION at Temperature °C 113.5 and Overvoltage 1.06
 Output Power on Load W:3634. Output Power of Transform. W:3634.
 Cu Losses W:41.64 Fe-Losses active W:18.67
 Short-Circuit-Volt. cold %:2.46 Regulation %:3.48
 Instantaneous pow. .5/958 W:4336. Efficiency of Transformer %:95.26
 dT Fe average Surface °K:65.6 dT primary °K:74.5
 dT Case aver. Surface °K:. dT secondary °K:

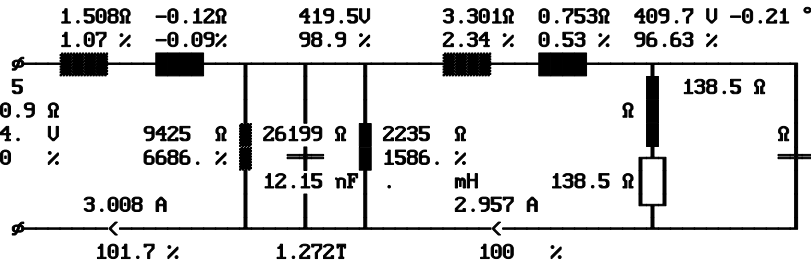

DUTY CYCLE OPERATION at Amb. Temperature °C 40. and Overvoltage 1.06
 dT Fe average Surface °K:65.6 dT primary °K:74.5
 dT Gehäuse av. Surface °K:. dT secondary °K:

NO LOAD OPERATION at Amb. Temperature °C 40. and Overvoltage 1.06
 Losses active W:20.06 Losses reactive UAr:80.56
 Current factor %:6.51 Induction T:1.285
 dT Fe average Surface °K:29.3 dT primary °K:24.2
 dT Gehäuse av. Surface °K:. Rezonance frequency kHz: .5

SHORT-CIRCUIT OPERATION at Amb. Temperature °C 40. and Overvoltage 1.06
 Losses active W:50944 Losses reactive UAr:9319.
 Current factor cold %:4060. Induction T: .897
 dT Fe average Surface °K:1320. dT primary °K:1923.
 dT Gehäuse av. Surface °K:. dT secondary °K:

PRIMARY (Tap:5) 1---- 2---- 3---- 4---- 5---- 6---- 7---- 8----
 Voltage Input/Output U:127.1 233.2 243.8 293.6 424.
 Out. Voltage no load U:131.4
 Current Input/Output A:9.533 3.008
 Load on output Ω:13.33
 Power factor of load :1.000
 Current in segment A:6.536 3.005 3.006 3.007 3.008
 Current density A/in²:1606. 1482. 1483. 1483. 1484.
 Icc-Current cold A:393.6 122.1
 Io -Current A: 0.196
 Inrush Current peak ^A: 29.26
 Inrush Current rms A: 12.29
 Cu-Losses W: 41.6
 Resistance cold Ω:.328 .9236 .9751 1.287 2.120
 Reactance Ω:.0929 .0563 .0004 .0141 .0916
 Eddy-Current Factor :1. 1. 1. 1. 1.

SECONDARY 1---- 2---- 3---- 4---- 5---- 6---- 7---- 8----
 Output Voltage U:
 Output Current A:
 Out. Voltage no load U:
 Sec. Voltage U:
 Sec. Current A:
 Current density A/in²:
 Sec. Voltage cold U:
 Load on output Ω:
 Power factor of load :
 Icc cold A:
 Cu-Losses warm W:
 Resistance cold Ω:
 Reactance Ω:
 Eddy-Current Factor :
 Capacitor mF:

Topic Battery Charger/ Design1

Designing rectifier transformer for battery charger 6Vdc, 40dc

Input parameters

Input	Voltage	120V, +-10%, 60Hz, sine wave
	Wire	Al, round, single insulated
Output	Nominal DC output voltage	6.3Vdc, via central tap, one phase rectifier with 2 diodes
	Nominal DC output current	40Adc, via central tap, one phase rectifier with 2 diodes
	Wire	Al, round, single insulated, wound bifilar
Core	Steel	M19, alternate stacking, not annealed
Bobbin	Type	Single section
Design	Insulation class	B, max. operating temperature 120C
	Criterion of design	16.6% regulation of the DC output voltage for battery charging between 2.45V/cell and 2.1V/cell
	Ambient temperature	40C

General rules

1. The cell voltage of an empty battery has amount of 2.1Vdc. If it is full then the voltage is between 2.35Vdc and 2.45Vdc per cell. The criterion of design has to be
Regulation:
Regulation = $100 \times (2.45-2.1)/2.2 = 16.6\%$
2. Due to the fact that the allowed regulation is relatively low we have to use only single section bobbin.
3. The transformers with Al wires are bigger, cooler but cheaper.

#*0	DIAGNOSE	Page 0
Name	:1 X EI 150/(3_1/2) 8535-0	
Steel	-:M19 Gauge 24 / 0.0250"	
Number of Sections	-:1	
max.Cu-Fill Factor	%:83.1	
max. parallel Wires	:2	
Induction on Load	T:1.354	
Max. Induction	T:1.386	
Max.Cu-Temp.rise on load	°K:58.3	
Max.Cu-Temp.rise no-load	°K:18.6	
Regulation	%:5.9	
I [^] Inrush/I [^] nom-Factor	*:28.4	
Input Current No-Load	%:20.	

Name : 1XEI 150/(3_1/2) 8535-0
 Steel : M19 Gauge 24 / 0.0250"

| F | B | A | B | F | | D |

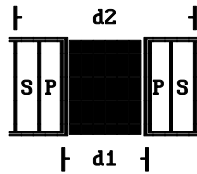
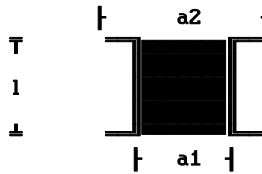
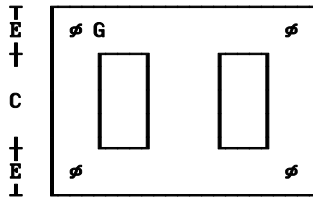

Weight /25.59
 lb:12.81
 Gap total in:0.000
 A-Limb in:1.50
 B-Width in:0.75
 C-Height in:2.25
 D-Stack in:3.50
 E-Yoke 1 in:0.75
 F-Yoke 2 in:0.75
 G-Hole in:0.233
 Radiator Fin :0
 Radiator Chan. :0
 a1 cm:1.64
 a2 cm:2.96
 d1 cm 3.63
 d2 cm 5.49
 l cm:2.12
 lp cm:
 ls cm:
 Margin cm:0.07

X- Length 1 in:
 Y- Width 1 in:
 Z- Height 1 in:
 x- Length 2 in:
 y- Width 2 in:
 z- Height 2 in:
 w- Thickness in:
 Material :
 Potted :

	Typ	Windun	MTI	DN	DN	Par	D/φ mil	B/φ mil	W/L	L	I/L mil	I/E mil	Weight lb	RWH %
1	1	99.	A00	15.5	15.5	1	53.9	53.9	36	2.7	.	10.	.241	27.
2														
3														
4														
5														
6														
7														
8														
1	23	5.0 bifilar	A00	6.5	6.5	2	153.	153.	12	1.6	.	.	.456	54.
2														
3														
4														
5														
6														
7														
8														
TOTAL													.698	83.

NOMINAL OPERATION at Temperature °C 98.1 and Overvoltage 1.00
 Output Power on Load W:252.5 Output Power of Transform. W:440.9
 Cu Losses W:26.63 Fe-Losses active W:13.49
 Short-Circuit-Volt. cold %:6.02 Regulation %:5.92
 Instantaneous pow. .5/958 W:1201. Efficiency of Transformer %:86.29
 dT Fe average Surface °K:47.9 dT primary °K:57.9
 dT Case aver. Surface °K:. dT secondary °K:58.4

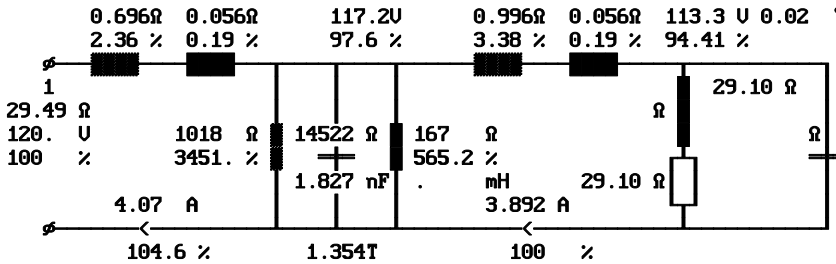

DUTY CYCLE OPERATION at Amb. Temperature °C 40. and Overvoltage 1.00
 dT Fe average Surface °K:47.9 dT primary °K:57.9
 dT Gehäuse av. Surface °K:. dT secondary °K:58.3

NO LOAD OPERATION at Amb. Temperature °C 40. and Overvoltage 1.00
 Losses active W:13.05 Losses reactive UAr:96.77
 Current factor %:20. Induction T:1.386
 dT Fe average Surface °K:19.7 dT primary °K:18.6
 dT Gehäuse av. Surface °K:. Rezonance frequency kHz:5.6

SHORT-CIRCUIT OPERATION at Amb. Temperature °C 40. and Overvoltage 1.00
 Losses active W:8096. Losses reactive UAr:519.5
 Current factor cold %:1661. Induction T:956
 dT Fe average Surface °K:1110. dT primary °K:1527.
 dT Gehäuse av. Surface °K:. dT secondary °K:1543.

PRIMARY (Tap:1) 1---- 2---- 3---- 4---- 5---- 6---- 7---- 8----
 Voltage Input/Output U:120.
 Out. Voltage no load U:
 Current Input/Output A:4.07
 Load on output Ω:
 Power factor of load :
 Current in segment A:4.07
 Current density A/in²:1783.
 Icc-Current cold A:67.61
 Io -Current A:0.814
 Inrush Current peak ^A:163.0
 Inrush Current rms A:70.63
 Cu-Losses W:11.5
 Resistance cold Ω:.5306
 Reactance Ω:.0561
 Eddy-Current Factor :1.

SECONDARY 1---- 2---- 3---- 4---- 5---- 6---- 7---- 8----
 Output Voltage U:6.28
 Output Current A:40.23
 Out. Voltage no load U:7.34
 Sec. Voltage U:5.72
 Sec. Current A:77.06
 Current density A/in²:2090.
 Sec. Voltage cold U:5.8
 Load on output Ω:.073
 Power factor of load :1.000
 Icc cold A:1335.
 Cu-Losses warm W:15.09
 Resistance cold Ω:.0019
 Reactance Ω:.0001
 Eddy-Current Factor :1.01
 Capacitor mF:349.2

Topic Welding/ Design1

Designing rectifier transformer for welding with 26Vdc, 200Adc

Input parameters

Input	Voltage	120V and 208V+-10%, 60Hz, sine wave
	Wire	Al, round, single insulated, wound outside
Output	Nominal DC output voltage	26Vdc, via one phase rectifier bridge and smoothing choke
	Nominal DC output current	200Adc during 1.5 minutes and 8.5 minutes pause
	Wire	Al, rectangular wire, wound inside
Core	Steel	M45, alternate stacking, not annealed
Bobbin	Type	Single section tube for EE 200/3" or EI long 150/75
Design	Insulation class	H, max. nominal g temperature 165°C at ambient temperature 40°C, ventilated with 3 ft/s airflow
	Criterion of design	Low price , high temperature rise

General rules

1. The welding transformers are normally forced cooled with airflow Over 3 ft/s
2. The welding transformers work in duty cycle operation mode and the winding losses are much higher than core losses. Due to this fact you can use cheap steel quality and relative high induction.
3. The welding transformers with Al wires are bigger, cooler but cheaper.
4. The welding transformers are always protected by a thermal fuse

##0	DIAGNOSE	Page 0
Name	:1 X EIL 200/(3)	
Steel	--:M45 Gauge 24 / 0.0250"	
Number of Sections	--:1	
max.Cu-Fill Factor	∴:71.5	
max. parallel Wires	:1	
Induction on Load	T:1.456	
Max. Induction	T:1.566	
Max.Cu-Temp.rise on load	°K:118.3	
Max.Cu-Temp.rise no-load	°K:40.8	
Regulation	∴:15.2	
I [^] Inrush/I [^] nom-Factor	*:8.7	
Input Current No-Load	∴:7.2	

PRIMARY	U(V) I(A)	SECOND. 1---	2---	3---	4---	5---	6---	7---	8---
Circuit-:1	120.	Circuit-:32							
Overult*:1.00	208.	Volta. U:26.							
Wire :-0.0	.	Curre. A:200.							
I/L. mil:1.	.	Wire :-4							
I/E. mil:1.	.	I/L mil:0.0							
Formfac.:1.11	.	I/E mil:10.0							
Fre.Hz:60	.								
dI/Io :100	.								

Regulat. %:50.0	Steel -:17	Cooling *:1.00	Bobbin -:1
Udiode U:1.5	Induction T:1.46	Force ft/s:3.00	P/S-Order -:2
dUdiode U:.1	Remanence *:0.35	Bracket -:1	Rac/Rdc *:1.10
Ripple %:5.	W/kg *:1.00	Radiator -:0	Space *:2.00
Tmp. Amb. °C:40	UAr/kg *:1.00	Chassis -:1.00	Vertical -:1
Tmp.rise °K:125	Gap *:1.00	Channel in:0.00	Horizontal -:1
Time 1 Min:1.5	Annealed -:0	Cu-Surface*:1.00	Impregnat. -:2
Load 1 *:1.0	Stacking *:1.00	Rth-uarni. *:1.00	Spread %:0
Time 2 Min:8.5	Hole -:1	Rth-comp. *:1.00	Selection -:1
Load 2 *:.0	Assembly -:1	Case -:0	Criterion -:2

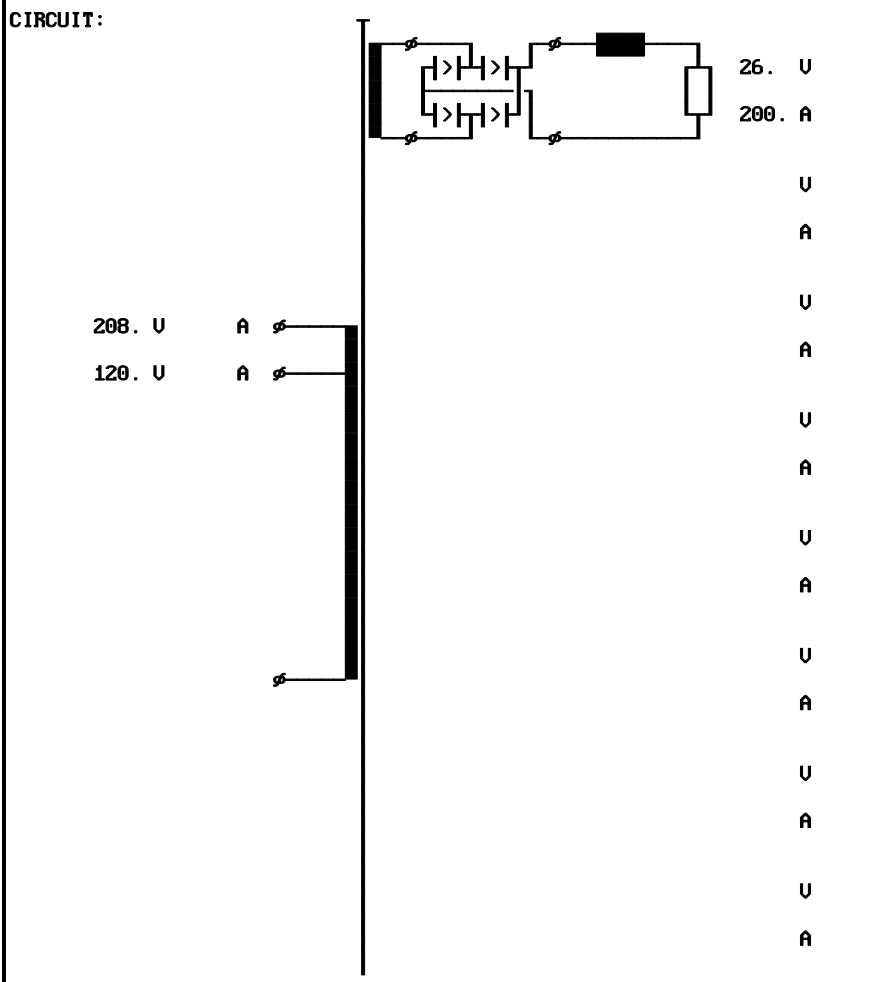

Name : 1XEIL 200 / (3)

Steel : M45 Gauge 24 / 0.0250"

/25.59

| F | B | A | B | F | | D |

Weight lb: 29.52

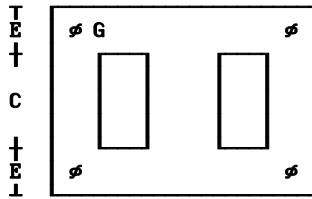

Gap total in: 0.000

A-Limb in: 2.00

B-Width in: 1.00

C-Height in: 6.00

D-Stack in: 3.00

E-Yoke 1 in: 1.00

F-Yoke 2 in: 1.00

G-Hole in: 0.31

Radiator Fin : 0

Radiator Chan. : 0

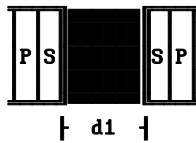
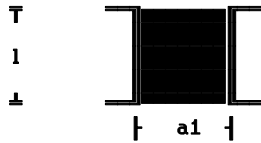

a1 cm: 2.18

a2 cm: 3.94

d1 cm: 3.16

d2 cm: 5.64

l cm: 5.78

lp cm:

ls cm:

Margin cm: 0.11

X- Length 1 in:
 Y- Width 1 in:
 Z- Height 1 in:
 x- Length 2 in:
 y- Width 2 in:
 z- Height 2 in:
 w- Thickness in:
 Material :
 Potted :

	Typ	Windun	MTI	DN	DN	Par	D/φ mil	B/φ mil	W/L	L	I/L mil	I/E mil	Weight lb	RWH %
1	1	76.5	A00	8.0	8.0	1	128.	128.	42	1.8	1.	1.	1.254	33.
2	1	132.5	A00	12.0	12.0	1	80.8	80.8	67	.83	1.	1.	.398	10.
3														
4														
5														
6														
7														
8														
1	32	24	A11	10.0	97.0	1	102.	410.	13	1.8	.	10.	1.097	27.
2														
3														
4														
5														
6														
7														
8														
TOTAL													2.749	71.

NOMINAL OPERATION at Temperature °C 158.2 and Overvoltage 1.00
 Output Power on Load W:5275. Output Power of Transfor. W:6526.
 Cu Losses W:994.6 Fe-Losses active W:88.79
 Short-Circuit-Volt. cold %:9.15 Regulation %:15.17
 Instantaneous pow. .5/958 W:11762 Efficiency of Transformer %:82.96
 dT Fe average Surface °K:210.9 dT primary °K:337.4
 dT Case aver. Surface °K:. dT secondary °K:339.3

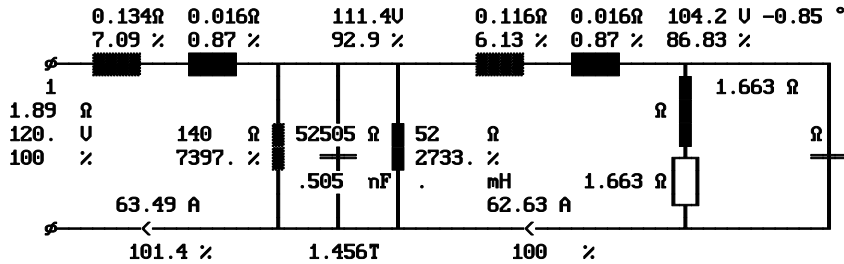

DUTY CYCLE OPERATION at Amb. Temperature °C 40. and Overvoltage 1.00
 dT Fe average Surface °K:61.9 dT primary °K:118.1
 dT Gehäuse av. Surface °K:. dT secondary °K:118.3

NO LOAD OPERATION at Amb. Temperature °C 40. and Overvoltage 1.00
 Losses active W:101.1 Losses reactive VAR:540.7
 Current factor %:7.22 Induction T:1.566
 dT Fe average Surface °K:49.1 dT primary °K:40.8
 dT Gehäuse av. Surface °K:. Resonance frequency kHz:19.1

SHORT-CIRCUIT OPERATION at Amb. Temperature °C 40. and Overvoltage 1.00
 Losses active W:81731 Losses reactive VAR:15799
 Current factor cold %:1092. Induction T:.771
 dT Fe average Surface °K:1968. dT primary °K:2638.
 dT Gehäuse av. Surface °K:. dT secondary °K:2696.

PRIMARY (Tap:1) 1---- 2---- 3---- 4---- 5---- 6---- 7---- 8----
 Voltage Input/Output U:120. 208.
 Out. Voltage no load U:
 Current Input/Output A:63.49
 Load on output Ω:
 Power factor of load :
 Current in segment A:63.49 0.
 Current density A/in²:4898. 0.
 Icc-Current cold A:693.7
 Io -Current A:4.584
 Inrush Current peak ^A:782.0
 Inrush Current rms A:366.1
 Cu-Losses W:540.1
 Resistance cold Ω:.0854 .2583
 Reactance Ω:.0164 .0088
 Eddy-Current Factor :1.01 1.

SECONDARY 1---- 2---- 3---- 4---- 5---- 6---- 7---- 8----
 Output Voltage U:26.2
 Output Current A:201.3
 Out. Voltage no load U:30.59
 Sec. Voltage U:32.42
 Sec. Current A:201.3
 Current density A/in²:4814.
 Sec. Voltage cold U:32.4
 Load on output Ω:.16
 Power factor of load :1.000
 Icc cold A:2228.
 Cu-Losses warm W:454.5
 Resistance cold Ω:.0072
 Reactance Ω:.0016
 Eddy-Current Factor :1.01
 Capacitor mF:.

Topic Audio/ Design1

Designing the audio transformer for loudspeaker 25W, 16_ Ohm

Input parameters

Input	Voltage	100V, 50-17000Hz, sine wave
	Wire	Cu, double insulated for small winding capacitance, wound outside
Output	Nominal output voltage	20V @ 50Hz, min 14.1V @ 17000Hz (-3dB)
	Nominal output current	1.25A @ 50Hz on 16 Ohm
	Wire	Cu, double insulated round wire for small winding capacitance, wound inside
Core	Steel	M6, annealed
	Assembly	Gaped EI core with 5 mil between E and I, for blocking amplifier DC bias current and the fine tuning of the resonance frequency
Bobbin	Type	Single section bobbin
Design	Criterion of design	<10% regulation

General rules

- In order to keep the leaking reactance low normally you'll use a single section bobbin. If the resonance frequency is lower than the maxim operating frequency (in this design 17000Hz) then you can reduce the capacitance (and increase the resonance frequency) using a double section bobbin. In that case 50% of the primary and 50% of the secondary are wound in each section.£

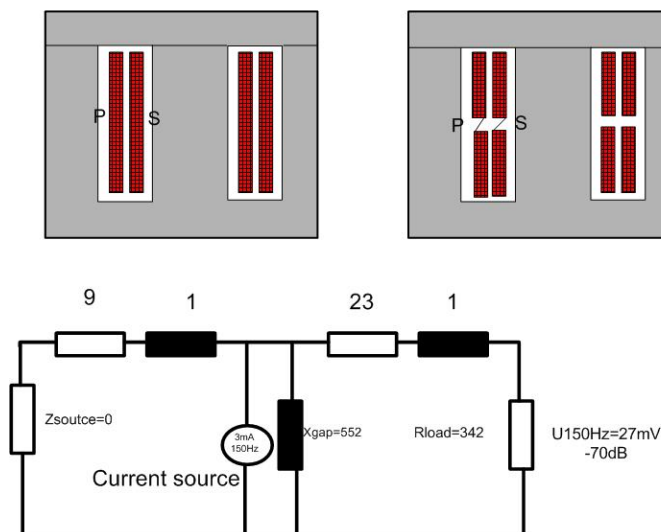

2. For a low amount of the winding capacitance you'll use a double or heavy insulated round wire. In some cases you'll also need to use the layer insulation.
3. Typical core assembly of a loudspeaker audio transformer is gaped EI or C cores with annealed grain oriented steel. In order to avoid the output voltage distortion through the current harmonics of the magnetizing current the maximal induction should not exceed 1.3T in an annealed EI core or 1.7T in a C core. In that case the third harmonic of the magnetizing current (no load current) will not exceed 10%-15% (in our design approx. 3mA, view "Results at 50Hz without gap")

With a gaped core assembly you can manipulate the resonance frequency changing the value of the no-load inductance. Additionally the gap will block the influence of the amplifier DC bias current.

4. At 17000Hz the output voltage is 15.85V (14.1V) and the phase delay 28.1°. If you would like to improve this operation mode then you need to reduce the eddy current losses (using litz wire) and the leaking reactance (using a long EI core with bigger Fe cross section). Note that the best results can be achieved using a toroidal core with minimum 8 sectors and one layer windings within each sector.

Results at 50Hz with gap

##0	DIAGNOSE	Page 0
Name	: 1 X EI 75/(2) 1126-0	
Steel	-: M111-0.35mm =>M6 0.014"	
Number of Sections	-: 1	
max.Cu-Fill Factor	%: 73.4	
max. parallel Wires	: 1	
Induction on Load	T: 1.301	
Max. Induction	T: 1.333	
Max.Cu-Temp.rise on load	°K: 34.	
Max.Cu-Temp.rise no-load	°K: 22.7	
Regulation	%: 9.8	
I [^] Inrush/I [^] nom-Factor	*: 14.1	
Input Current No-Load	%: 91.1	

PRIMARY	U(U) I(A)	SECOND.	1---	2---	3---	4---	5---	6---	7---	8---
Circuit--:1	100.	Circuit--:11								
Overvlt*:1.00	.	Volta. U:20.								
Wire :2.0	.	Curre. A:1.25								
I/L. mil:0.	.	Wire :2								
I/E. mil:10.	.	I/L mil:0.0								
Formfac.:1.11	.	I/E mil:5.0								
Fre.Hz:50	.									
dI/Io :100	.									

Regulat. %:8.0	Steel -:1	Cooling *:1.00	Bobbin -:1
Udiode U:1.5	Induction T:1.30	Force ft/s:0.00	P/S-Order -:2
dUdiode U:.1	Remanence *:0.35	Bracket -:1	Rac/Rdc *:1.05
Ripple %:5.	W/kg *:1.00	Radiator -:0	Space *:0.90
Tmp. Amb. °C:40	UAr/kg *:1.00	Chassis -:1.00	Vertical -:1
Tmp.rise °K:20	Gap *:5.00	Channel in:0.00	Horizontal -:1
Time 1 Min:30.0	Annealed -:1	Cu-Surface*:1.00	Impregnat. -:3
Load 1 *:1.0	Stacking *:1.00	Rth-uarni. *:1.00	Spread %:0
Time 2 Min:30.0	Hole -:1	Rth-comp. *:1.00	Selection -:2
Load 2 *:1.0	Assembly -:2	Case -:0	Criterion -:1

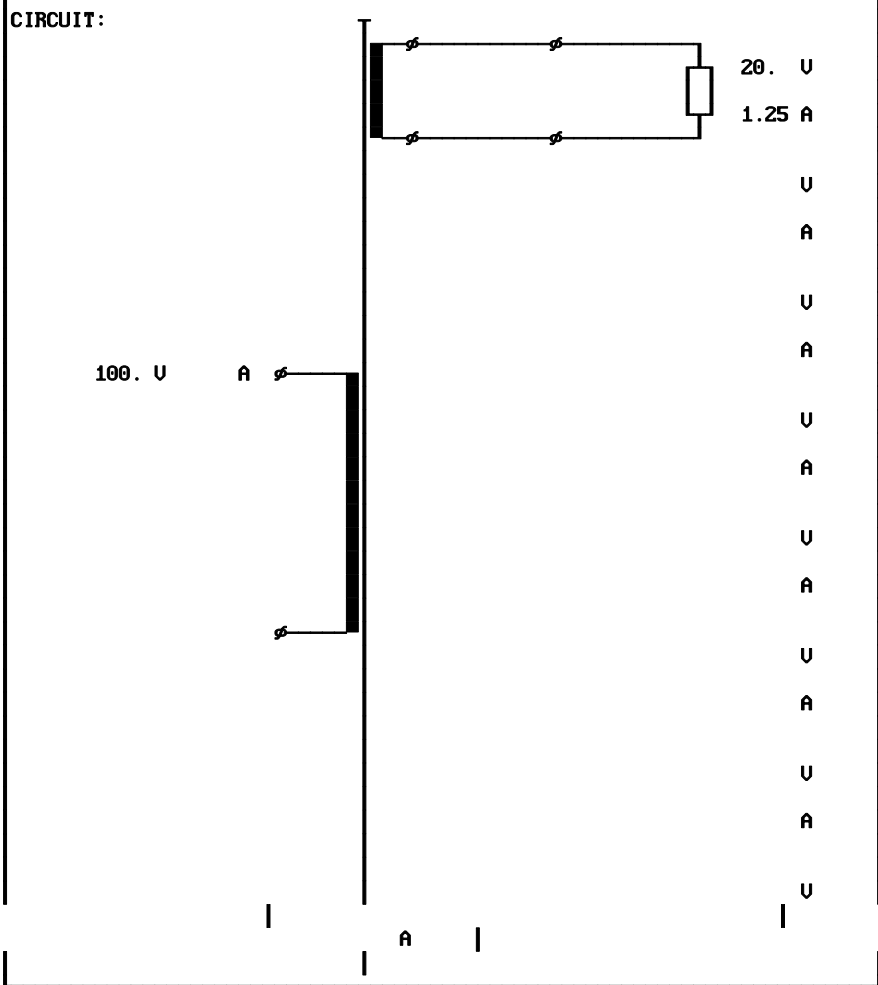

Name :1XEI 75/(2) 1126-0
 Steel :M111-0.35mm =>M6 0.014"

| F | B | A | B | F | | D |

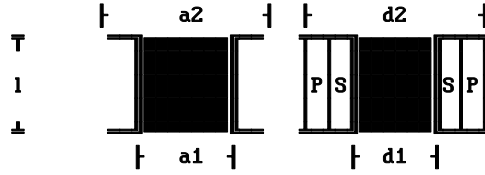
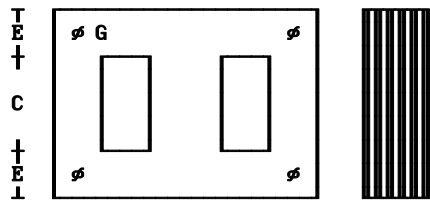

Weight lb:1.82
 Gap total in:0.000
 A-Limb in:0.75
 B-Width in:0.38
 C-Height in:1.13
 D-Stack in:2.03
 E-Yoke 1 in:0.38
 F-Yoke 2 in:0.38
 G-Hole in:0.00
 Radiator Fin :0
 Radiator Chan. :0
 a1 cm:0.84
 a2 cm:1.49
 d1 cm 2.10
 d2 cm 2.73
 l cm:1.03
 lp cm:
 ls cm:
 Margin cm:0.05

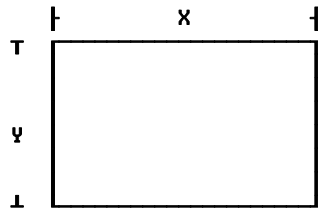

X- Length 1 in:
 Y- Width 1 in:
 Z- Height 1 in:
 x- Length 2 in:
 y- Width 2 in:
 z- Height 2 in:
 w- Thickness in:
 Material :
 Potted :

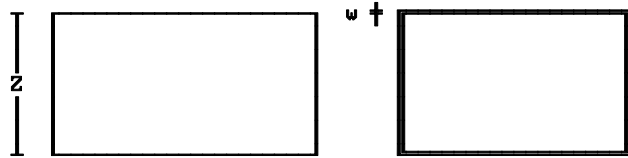

	Typ	Windun	MTI	DN	DN	Par	D/φ mil	B/φ mil	W/L	L	I/L mil	I/E mil	Weight lb	RWH %
1	1	356.	C02	25.5	25.5	1	16.9	16.9	49	7.2	.	10.	.172	52.
2														
3														
4														
5														
6														
7														
8														
1	11	77.0	C02	23.5	23.5	1	21.3	21.3	40	1.9	.	5.	.053	17.
2														
3														
4														
5														
6														
7														
8														
TOTAL													.225	73.

NOMINAL OPERATION at Temperature °C 72.2 and Overvoltage 1.00
 Output Power on Load W:24.26 Output Power of Transfor. W:24.26
 Cu Losses W:4.86 Fe-Losses active W:.73
 Short-Circuit-Volt. cold %:15.85 Regulation %:9.79
 Instantaneous pow. .5/95& W:57.9 Efficiency of Transformer %:81.29
 dT Fe average Surface °K:24.6 dT primary °K:34.
 dT Case aver. Surface °K:. dT secondary °K:30.4

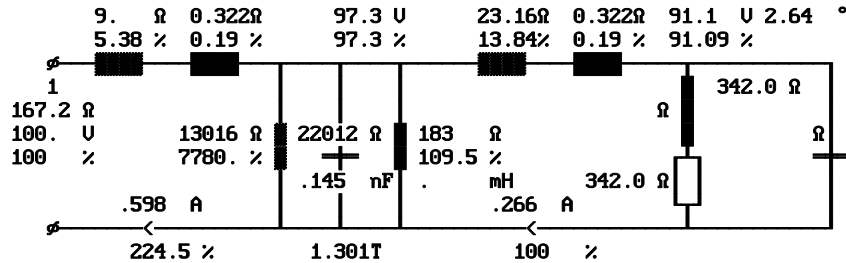

DUTY CYCLE OPERATION at Amb. Temperature °C 40. and Overvoltage 1.00
 dT Fe average Surface °K:24.5 dT primary °K:34.
 dT Gehäuse av. Surface °K:. dT secondary °K:30.4

NO LOAD OPERATION at Amb. Temperature °C 40. and Overvoltage 1.00
 Losses active W:3.4 Losses reactive UAr:54.36
 Current factor %:91.11 Induction T:1.333
 dT Fe average Surface °K:16.2 dT primary °K:22.7
 dT Gehäuse av. Surface °K:. Rezonance frequency kHz:17.3

SHORT-CIRCUIT OPERATION at Amb. Temperature °C 40. and Overvoltage 1.00
 Losses active W:375.2 Losses reactive UAr:37.41
 Current factor cold %:630.9 Induction T:.972
 dT Fe average Surface °K:267.2 dT primary °K:410.2
 dT Gehäuse av. Surface °K:. dT secondary °K:448.3

PRIMARY (Tap:1) 1---- 2---- 3---- 4---- 5---- 6---- 7---- 8----
 Voltage Input/Output U:100.
 Out. Voltage no load U:
 Current Input/Output A:0.598
 Load on output Ω:
 Power factor of load :
 Current in segment A:0.598
 Current density A/in²:2665.
 Icc-Current cold A:3.77
 Io -Current A:0.545
 Inrush Current peak ^A:11.89
 Inrush Current rms A:4.82
 Cu-Losses W:3.2
 Resistance cold Ω:7.406
 Reactance Ω:.3221
 Eddy-Current Factor :1.

SECONDARY 1---- 2---- 3---- 4---- 5---- 6---- 7---- 8----
 Output Voltage U:19.7
 Output Current A:1.231
 Out. Voltage no load U:21.55
 Sec. Voltage U:19.7
 Sec. Current A:1.231
 Current density A/in²:3455.
 Sec. Voltage cold U:19.7
 Load on output Ω:16.
 Power factor of load :1.000
 Icc cold A:17.28
 Cu-Losses warm W:1.643
 Resistance cold Ω:.9024
 Reactance Ω:.0151
 Eddy-Current Factor :1.
 Capacitor mF:.

Results at 17000Hz

08-22-2008/09:38:43	General Data	Page 3
<p>NOMINAL OPERATION at Temperature °C 59.9 and Overvoltage 1.00</p> <p>Output Power on Load W:15.71 Output Power of Transfor. W:15.71</p> <p>Cu Losses W:3.11 Fe-Losses active W:.14</p> <p>Short-Circuit-Volt. cold %:47.66 Regulation %:36.43</p> <p>Instantaneous pow. .5/958 W:9.2 Efficiency of Transformer %:82.88</p> <p>dT Fe average Surface °K:15.8 dT primary °K:19.5</p> <p>dT Case aver. Surface °K:. dT secondary °K:20.3</p>		
<p>15.77Ω 109.5Ω 87.5 U 51.45Ω 109.5Ω 73.3 U -28.1 °</p> <p>3.42 % 23.77% 87.5 % 11.17% 23.77% 73.3 %</p> <p>460.7 Ω 342.0 Ω</p> <p>100. U 55624 Ω 64743 Ω 15114 Ω</p> <p>100 % 12073 % 3200. %</p> <p>.217 A .145 nF .214 A</p> <p>101.3 % .003 T 100 %</p>		
<p>DUTY CYCLE OPERATION at Amb. Temperature °C 40. and Overvoltage 1.00</p> <p>dT Fe average Surface °K:15.8 dT primary °K:19.5</p> <p>dT Gehäuse av. Surface °K:. dT secondary °K:20.3</p>		
<p>NO LOAD OPERATION at Amb. Temperature °C 40. and Overvoltage 1.00</p> <p>Losses active W:.18 Losses reactive VAR:.44</p> <p>Current factor %:2.21 Induction T:.004</p> <p>dT Fe average Surface °K:1.3 dT primary °K:1.2</p> <p>dT Gehäuse av. Surface °K:. Resonance frequency kHz:35.2</p>		
<p>SHORT-CIRCUIT OPERATION at Amb. Temperature °C 40. and Overvoltage 1.00</p> <p>Losses active W:5.5 Losses reactive VAR:45.21</p> <p>Current factor cold %:209.8 Induction T:.002</p> <p>dT Fe average Surface °K:29.2 dT primary °K:37.7</p> <p>dT Gehäuse av. Surface °K:. dT secondary °K:38.8</p>		
<p>PRIMARY (Tap:1) 1---- 2---- 3---- 4---- 5---- 6---- 7---- 8----</p> <p>Voltage Input/Output U:100.</p> <p>Out. Voltage no load U:</p> <p>Current Input/Output A:0.217</p> <p>Load on output Ω:</p> <p>Power factor of load :</p> <p>Current in segment A:0.217</p> <p>Current density A/in²:967.7</p> <p>Icc-Current cold A:0.46</p> <p>Io -Current A:0.005</p> <p>Inrush Current peak ^A:0.</p> <p>Inrush Current rms A:0.</p> <p>Cu-Losses W:.7</p> <p>Resistance cold Ω:7.406</p> <p>Reactance Ω:109.5</p> <p>Eddy-Current Factor :1.84</p>		
<p>SECONDARY 1---- 2---- 3---- 4---- 5---- 6---- 7---- 8----</p> <p>Output Voltage U:15.85</p> <p>Output Current A:0.991</p> <p>Out. Voltage no load U:21.52</p> <p>Sec. Voltage U:15.85</p> <p>Sec. Current A:0.991</p> <p>Current density A/in²:2780.</p> <p>Sec. Voltage cold U:15.9</p> <p>Load on output Ω:16.</p> <p>Power factor of load :1.000</p> <p>Icc cold A:2.08</p> <p>Cu-Losses warm W:2.363</p> <p>Resistance cold Ω:.9024</p> <p>Reactance Ω:5.123</p> <p>Eddy-Current Factor :2.3</p> <p>Capacitor mF:.</p>		

Results at 50Hz withot gap

08-22-2008/09:40:39	General Data	Page 3
<p>NOMINAL OPERATION at Temperature °C 57.7 and Overvoltage 1.00</p> <p>Output Power on Load W:24.58 Output Power of Transfor. W:24.58</p> <p>Cu Losses W:2.25 Fe-Losses active W:.74</p> <p>Short-Circuit-Volt. cold %:7.36 Regulation %:9.06</p> <p>Instantaneous pow. .5/958 W:60.6 Efficiency of Transformer %:89.16</p> <p>dT Fe average Surface °K:14.9 dT primary °K:17.4</p> <p>dT Case aver. Surface °K:. dT secondary °K:18.</p>		
<p>8.515Ω 0.322Ω 97.6 U 22.21Ω 0.322Ω 91.7 U -0.03 °</p> <p>2.35 % 0.09 % 97.6 % 6.13 % 0.09 % 91.69 %</p> <p>1 362.1 Ω 100. U 100 % 12820 Ω 22012 Ω 6416 Ω 342.0 Ω</p> <p>.276 A .145 nF .268 A 342.0 Ω</p> <p>103. % 1.307T 100 %</p>		
<p>DUTY CYCLE OPERATION at Amb. Temperature °C 40. and Overvoltage 1.00</p> <p>dT Fe average Surface °K:14.9 dT primary °K:17.4</p> <p>dT Gehäuse av. Surface °K:. dT secondary °K:18.</p>		
<p>NO LOAD OPERATION at Amb. Temperature °C 40. and Overvoltage 1.00</p> <p>Losses active W:.85 Losses reactive VAR:1.59</p> <p>Current factor %:6.52 Induction T:1.337</p> <p>dT Fe average Surface °K:5.1 dT primary °K:4.7</p> <p>dT Gehäuse av. Surface °K:. Rezonance frequency kHz:2.9</p>		
<p>SHORT-CIRCUIT OPERATION at Amb. Temperature °C 40. and Overvoltage 1.00</p> <p>Losses active W:374.8 Losses reactive VAR:9.59</p> <p>Current factor cold %:1357. Induction T: 975</p> <p>dT Fe average Surface °K:266.1 dT primary °K:403.7</p> <p>dT Gehäuse av. Surface °K:. dT secondary °K:447.</p>		
<p>PRIMARY (Tap:1) 1---- 2---- 3---- 4---- 5---- 6---- 7---- 8----</p> <p>Voltage Input/Output U:100.</p> <p>Out. Voltage no load U:</p> <p>Current Input/Output A:0.276</p> <p>Load on output Ω:</p> <p>Power factor of load :</p> <p>Current in segment A:0.276</p> <p>Current density A/in²:1231.</p> <p>Icc-Current cold A:3.75</p> <p>Io -Current A:0.018</p> <p>Inrush Current peak ^A:11.89</p> <p>Inrush Current rms A:4.82</p> <p>Cu-Losses W:.6</p> <p>Resistance cold Ω:7.406</p> <p>Reactance Ω:.3221</p> <p>Eddy-Current Factor :1.</p>		
<p>SECONDARY 1---- 2---- 3---- 4---- 5---- 6---- 7---- 8----</p> <p>Output Voltage U:19.83</p> <p>Output Current A:1.24</p> <p>Out. Voltage no load U:21.61</p> <p>Sec. Voltage U:19.83</p> <p>Sec. Current A:1.24</p> <p>Current density A/in²:3478.</p> <p>Sec. Voltage cold U:19.8</p> <p>Load on output Ω:16.</p> <p>Power factor of load :1.000</p> <p>Icc cold A:17.31</p> <p>Cu-Losses warm W:1.597</p> <p>Resistance cold Ω:.9024</p> <p>Reactance Ω:.0151</p> <p>Eddy-Current Factor :1.</p> <p>Capacitor mF:.</p>		

Topic Capacitor Charger / Design1

Designing flyback transformer for capacitor charger 10kVdc, 0.1 μF, 50W

In order to design a flyback C-charger transformer with the Rale Design Software you need the following inputs:

- Min. input voltage and the duty cycle (t_{on} & t_{off}) at this voltage
- DC-output voltages and DC-output currents
- The ripple of the ampere-turns (induction)
- Frequency

There are 2 typical operation modes:

- Continuous mode $t_s > t_{off}$
- Discontinuous mode $t_s \leq t_{off}$ (typical for C-charging)

The charging & discharging of a capacitor is a dynamic procedure (view the next Figure). Due to the fact that there is no constant output voltage & current you need to determine by hand (from thermal point of view) the equivalent output voltage and the equivalent output current

Note that a flyback transformer is very suitable for charging a capacitor with constant power. In this operating mode the electronic has to control the constant frequency, the constant t_{on} time and the maximal capacitor output voltage U_c .

During the charging period T_p the capacitor C is empty ($U_c = 0$) and the secondary current will drop down with the formula:

$$i_2 = I_m \cos(\omega t)$$

Where:

$$\omega = (L_2 C)^{-0.5}$$

For $i_2 = 0$, $\omega t_{off} = \pi/2$, $t_{off} = t_s = 900 \mu s$, $t_{on} = 100 \mu s$, $T_L = 0.1 s$, $U_{cmax} = 10000 V$ and $P = 50 W$ we can calculate (without losses):

- The inductance of the secondary winding for the resonance frequency $1/4 t_{off}$
 $L_2 = (2 t_{off} / \pi)^2 / C = (2 \cdot 0.0009 / 3.14)^2 / 0.0000001 = 3.37 H$
- The average value of the source current (without losses)
 $I_{1av} = P / U_1 = 50 / 150 = 0.333 A$
- The peak value of the source current
 $I_{1peak} = 2 I_{1av} T_p / t_{on} = 2 \cdot 0.333 \cdot 1000 / 100 = 6.66 A$
- The inductance of the primary winding
 $L_1 = U_1 t_{on} / I_{1peak} = 2.25 mH$
- The turns ration of the primary & secondary windings
 $W_1 / W_2 = (L_1 / L_2)^{0.5} = (0.00225 / 3.37)^{0.5} = 0.0258$
- The RMS value of the output current during the charging time T_L
 $I_{o.th} = (P C \ln(T_L / T_p) / 2 / T_L)^{0.5} = (50 \cdot 0.0000001 \ln(0.1 / 0.001) / 2 / 0.1)^{0.5} = 34 mA$
- The output voltage at the output current 34mA
 $U_{c0.th} = P / I_{o.th} = 50 / 0.034 = 1470 V$

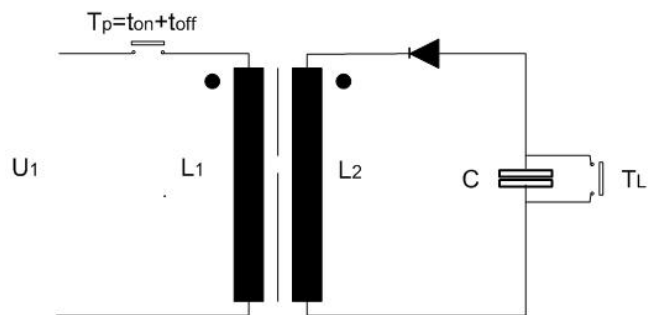
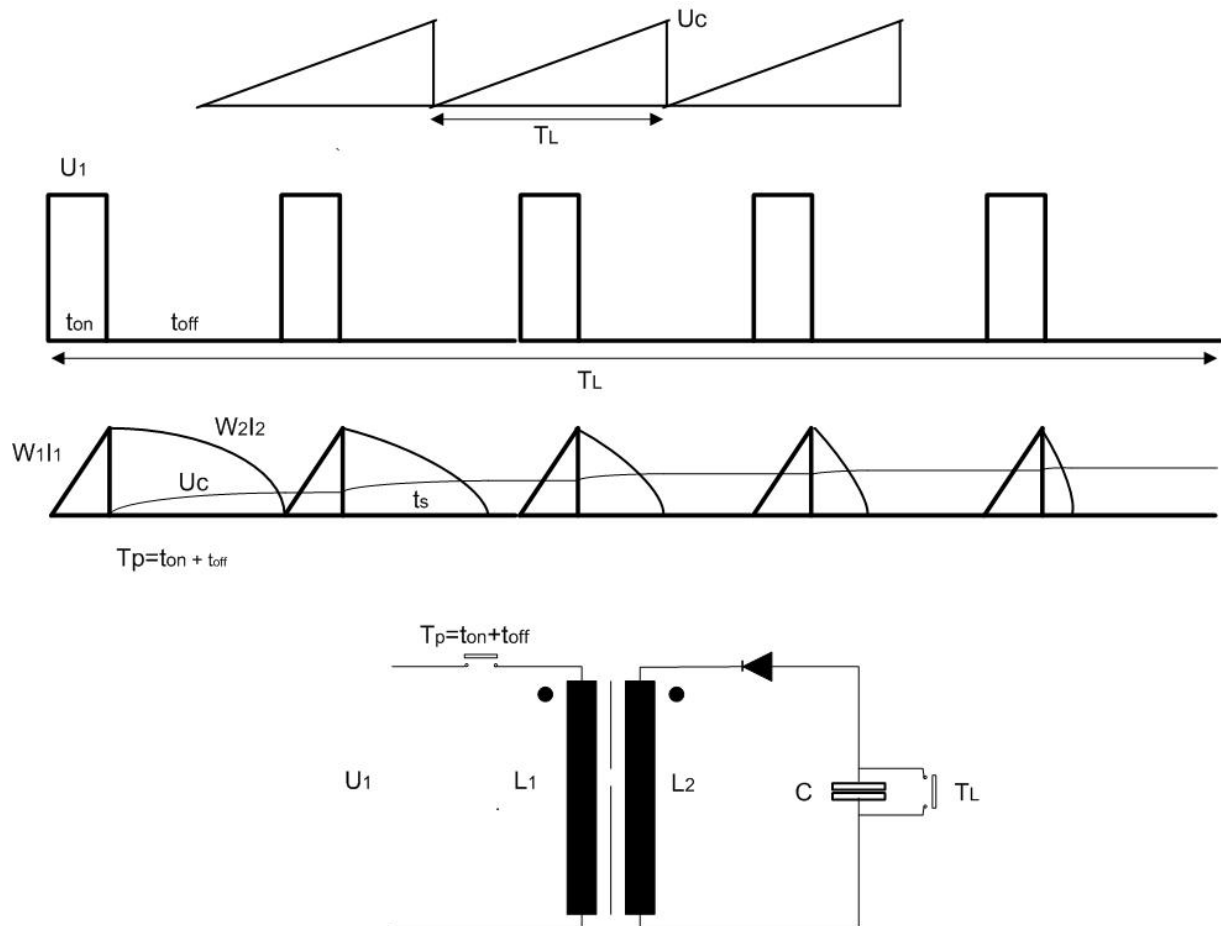

Input parameters

Input	Voltage	150V, 1000Hz, $t_{on} = 100\mu s$, $t_{off} = 900\mu s$
	Wire	Cu, round, single insulated
Output	Nominal DC output voltage	Nominal 1470V, max. 10000V
	Nominal DC output current	Nominal 34mA, min. 5mA
	Wire	Cu, round, double insulated, wound outside
Core	Steel	Ferrite N27
Bobbin	Type	Single section, potted
Design	Insulation class	E, max. operating temperature 120C
	Criterion of design	Temperature rise
	Ambient temperature	40C

General rules

1. Before you start designing of the flybyck transformer with the above specified input parameters you have to set the **Form Factor** and the **dI/Io** :

$$\text{Form Factor} = T_p/2/t_{on}$$

$$dI/I_o = 100 t_{off}/t_s$$

These 2 input parameters can be calculated if you set $q = t_{on}/T_p$ & $s = t_s/T_p$ or $L1$ & $W1/W2$ in the following input mask:

Flyback Input Form

Min. input volatage U: 150

Outputvoltage U: 1470

Output power W: 49.98

Frequency Hz: 1000

$q = T_{on}/(T_{on}+T_{off})$: 0.105

$s = T_s/(T_{on}+T_{off})$: 0.415

Primary inductance mH: 2.25

Turns ratio W_{prim}/W_{sec} : 0.0258

Form factor = $0.5/q$: 4.77

$dI_o/I = 100*(1-q)/s$ %: 215.8

OK **Cancel**

dl/I (%) = 100*Toff/Ts
Formfactor= (1+Toff/Ton)/2
q=Ton/(Ton+Toff)

2. Note that discharging time t_s varies during the time T_L from $900 \mu s$ to $71 \mu s$. Due to this fact the operating flyback frequency can not be selected very high. If the output voltage is over the bobbin testing voltage and the transformer has to be potted then the flyback operating frequency has to be selected less than 2-3kHz.
3. If the commutating losses in the primary leaking inductance are too high then you need to increase t_{on} time.

Design at nominal operation mode 1470V @ 34mA

#*0	DIAGNOSE	Page 0
Name	:1 X ETD 59 B66397	
Steel	-:N27 <SIEMENS 200k	
Number of Sections	-:1	
max. Cu-Fill Factor	%:85.3	
max. parallel Wires	:1	
Induction on Load	T:0.126	
Max. Induction	T:0.267	
Max. Cu-Temp. rise on load	°K:50.5	
Max. Cu-Temp. rise no-load	°K:.	
Regulation	%:.	
I^Inrush/I^nom-Factor	*:.	
Input Current No-Load	%:.	

PRIMARY	U(V)	I(A)	SECOND.	1---	2---	3---	4---	5---	6---	7---	8---
Circuit-:1	150.		Circuit-:35								
Overvlt*:1.00	.		Volta. U:1470								
Wire :0.0	.		Curre. A:.034								
I/L. mil:0.	.		Wire :1								
I/E. mil:10.	.		I/L mil:2.0								
Formfac.:4.76	.		I/E mil:2.0								
Fre.Hz:1000	.										
dI/Io :213	.										

Regulat. %:50.0	Steel -:-3	Cooling *:1.00	Bobbin -:-1
Udiode U:0.8	Induction T:0.27	Force ft/s:0.00	P/S-Order -:-1
dUdiode U:.1	Remanence *:0.00	Bracket -:-1	Rac/Rdc *:1.25
Ripple %:5.	W/kg *:1.00	Radiator -:-0	Space *:0.90
Tmp. Amb. °C:40	UAr/kg *:1.00	Chassis -:-1.00	Vertical -:-0
Tmp.rise °K:50	Gap *:0.00	Channel in:0.00	Horizontal -:-1
Time 1 Min:30.0	Annealed -:-1	Cu-Surface*:1.00	Impregnat. -:-4
Load 1 *:1.0	Stacking *:1.00	Rth-varni. *:1.00	Spread %:0
Time 2 Min:30.0	Hole -:-1	Rth-comp. *:1.00	Selection -:-2
Load 2 *:1.0	Assembly -:-2	Case -:-0	Criterion -:-2

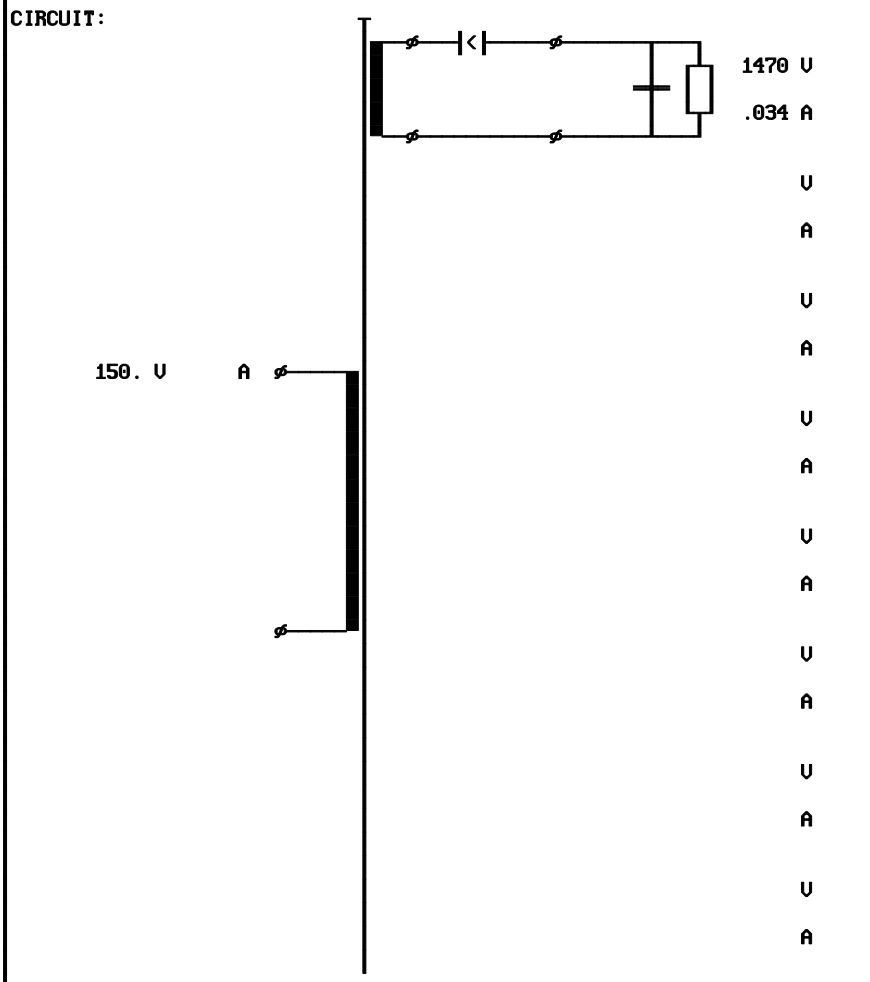

Name :1XETD 59 B66397
 Steel :N27 <SIEMENS 200k

| F | B | A | B | F | | D=A |

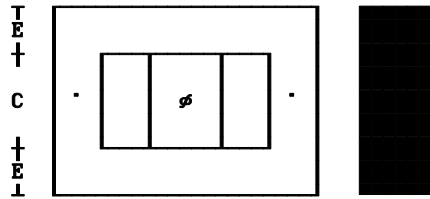

Weight lb: .61
 Gap total in: 0.211
 A-Limb in: 0.87
 B-Width in: 0.42
 C-Height in: 1.73
 D-Stack in: 0.87
 E-Yoke 1 in: 0.36
 F-Yoke 2 in: 0.34
 G-Hole in: 0.00
 Radiator Fin : 0
 Radiator Chan. : 0
 a1 cm: 0.97
 a2 cm: 1.67
 d1 cm: 0.97
 d2 cm: 1.67
 l cm: 1.61
 lp cm:
 ls cm:
 Margin cm: 0.06

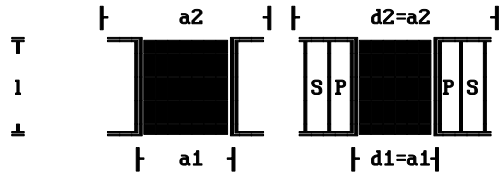

X- Length 1 in:
 Y- Width 1 in:
 Z- Height 1 in:
 x- Length 2 in:
 y- Width 2 in:
 z- Height 2 in:
 w- Thickness in:
 Material :
 Potted :

	Typ	Windun	MTI	DN	DN	Par	D/φ mil	B/φ mil	W/L	L	I/L mil	I/E mil	Weight lb	RWH %
1	1	154.1	C00	19.5	19.5	1	33.9	33.9	44	3.5	.	10.	.153	36.
2														
3														
4														
5														
6														
7														
8														
1	35	7045.1	C01	37.5	37.5	1	4.2	4.2	303	23.	2.	2.	.137	46.
2														
3														
4														
5														
6														
7														
8														
TOTAL													.29	85.

NOMINAL OPERATION at Temperature °C 90.1 and Overvoltage 1.00
 Output Power on Load W:58.31 Output Power of Transform. W:74.99
 Cu Losses W:8.49 Fe-Losses active W:.04
 Short-Circuit-Volt. cold %: Regulation %:
 Instantaneous pow. .5/958 W: Efficiency of Transformer %:82.85
 dT Fe average Surface °K:46.3 dT primary °K:49.7
 dT Case aver. Surface °K:. dT secondary °K:50.5

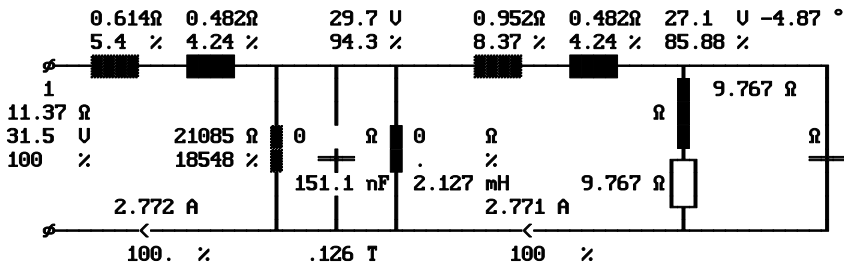

DUTY CYCLE OPERATION at Amb. Temperature °C 40. and Overvoltage 1.00
 dT Fe average Surface °K:46.3 dT primary °K:49.7
 dT Case aver. Surface °K:. dT secondary °K:50.5

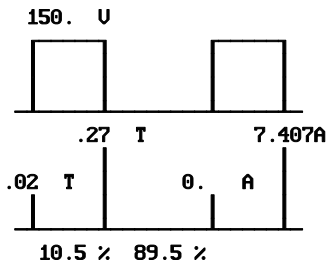

Frequency Hz:1000.
 Rezonance frequency kHz:8.9
 Input voltage U:150.
 Relative turn on time %:10.5
 Relative turn off time %:89.5
 Rel.duty cycle s.current %:42.
 Ripple (input current) %:100.
 Min. Induction/Current T-A:0.02 /0.
 Max. Induction/Current T-A:.27 /7.407
 No-load inductance mH:2.127
 Ripple (output voltage) %:5.

PRIMARY (Tap:1) 1---- 2---- 3---- 4---- 5---- 6---- 7---- 8----
 Input voltage U:150.
 :
 Input current rms. A:1.386
 :
 :
 Current in segment A:1.386
 Current dencity A/in^2:
 :
 :
 Min. input current ^A:0.
 Max. input current ^A:7.407
 Cu-Losses W:1.2
 Resistance cold Ω:4069
 Leaking reactance Ω:4816
 Eddy-Current Factor :1.18

SECONDARY 1---- 2---- 3---- 4---- 5---- 6---- 7---- 8----
 Output Voltage U:1713.
 Output current dc A:0.034
 :
 Secondary curr. rms %:0.061
 :
 :
 Current dencity A/in^2:
 Secondary curr. min ^A:0.
 Secondary curr. max ^A:0.162
 :
 :
 Cu-losses warm W:7.307
 Resistance cold Ω:1550.
 Leaking reactance Ω:1006.
 Eddy-current factor :1.
 Capacitor mF:.
 Capacitor curr. rms A:.05

Design at maximal output voltage 10000V @ 5mA

08-29-2008/18:15:50	General Data	Page 3
<p>NOMINAL OPERATION at Temperature °C 54.6 and Overvoltage 1.00</p> <p>Output Power on Load W:55.56 Output Power of Transfor. W:32.59</p> <p>Cu Losses W:1.96 Fe-Losses active W:.05</p> <p>Short-Circuit-Volt. cold %: Regulation %:.</p> <p>Instantaneous pow. .5/95& W: Efficiency of Transformer %:97.03</p> <p>dT Fe average Surface °K:13.7 dT primary °K:14.6</p> <p>dT Case aver. Surface °K:.. dT secondary °K:14.5</p>		
<p>DUTY CYCLE OPERATION at Amb. Temperature °C 40. and Overvoltage 1.00</p> <p>dT Fe average Surface °K:13.7 dT primary °K:14.6</p> <p>dT Case aver. Surface °K:.. dT secondary °K:14.5</p>		
<p>Frequency Hz:1000.</p> <p>Rezonance frequency kHz:8.9</p> <p>Input voltage U:150.</p> <p>Relative turn on time %:10.5</p> <p>Relative turn off time %:89.5</p> <p>Rel.duty cycle s.current %:7.1</p> <p>Ripple (input current) %:100.</p> <p>Min. Induction/Current T-A:.01 /0.</p> <p>Max. Induction/Current T-A:.27 /7.416</p> <p>No-load inductance mH:2.124</p> <p>Ripple (output voltage) %:5.</p>		
<p>PRIMARY (Tap:1) 1---- 2---- 3---- 4---- 5---- 6---- 7---- 8----</p> <p>Input voltage U:150.</p> <p>Input current rms. A:1.322</p> <p>Current in segment A:1.322</p> <p>Current dencity A/in^2:</p> <p>Min. input current ^A:0.</p> <p>Max. input current ^A:7.416</p> <p>Cu-Losses W:1.</p> <p>Resistance cold Ω:.4066</p> <p>Leaking reactance Ω:.4808</p> <p>Eddy-Current Factor :1.18</p>		
<p>SECONDARY 1---- 2---- 3---- 4---- 5---- 6---- 7---- 8----</p> <p>Output Voltage U:10111</p> <p>Output current dc A:0.005</p> <p>Secondary curr. rms %:0.024</p> <p>Current dencity A/in^2:</p> <p>Secondary curr. min ^A:0.</p> <p>Secondary curr. max ^A:0.154</p> <p>Cu-losses warm W:1.001</p> <p>Resistance cold Ω:1550.</p> <p>Leaking reactance Ω:1006.</p> <p>Eddy-current factor :1.</p> <p>Capacitor mF:.</p> <p>Capacitor curr. rms A:.023</p>		